

# SMA INNER DC BLOCK .01-3GHZ

SD3247

## SPECIFICATIONS

### ELECTRICAL:

FREQUENCY: 0.01-3 GHZ

INSERTION LOSS: 0.2 DB MAX 2GHZ; .35@3GHZ

VSWR 1.25 MAX

BREAKDOWN VOLTAGE: 200 VOLTS

MATERIALS, BODY: PASSIVATED STAINLESS STEEL

OP TEMPERATURE: -55 TO +125 DEG C

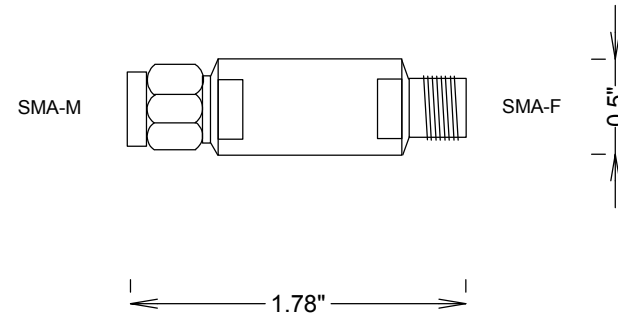

CENTER PIN HAS DC BLOCKING CAP

**FAIRVIEW MICROWAVE INC.**

ALLEN, TX 75013 WWW.FAIRVIEWMICROWAVE.COM

TITLE

**SMA INNER DC BLOCK .01-3GHZ**

SIZE	CAGE CODE	DWG NO	REV
<b>A</b>	<b>3FKR5</b>	<b>SD3247</b>	

SCALE

SHEET