

MC-Card Microminiature RF Connectors

MC-Card series are microminiature, 50-ohm connectors that feature snap-on mating and a frequency range of DC–6 GHz.

MC-Card connectors are an alternative to MMCX connectors in many wireless and telecom applications.

They are similar to MMCX in performance, feature quick snap-on mating and unmating, and are designed to withstand a minimum of 5,000 mating cycles.

Delta MC-Card connectors are available for several sizes of flexible cable, and as PCB receptacles.

The edge-card switching receptacles on page 4 automatically switch from an internal circuit and an external circuit when mated. They are ideal for use in applications such as portable computers operating in wireless networks, allowing for automatic switching between the internal antenna and a higher-gain external antenna.

Specifications*

Electrical:

Nominal Impedance: 50 ohms.

Frequency Range: DC–6 GHz (DC–3 GHz for internal circuit of switching receptacles;
DC–8.5 GHz for external circuit of switching receptacles).

Voltage Rating: 100 VRMS max.

Dielectric Withstanding Voltage: 250 VRMS min.

Contact Resistance: Center contact, 5 milliohms max;
Outer contact, 3 milliohms max.

Insulation Resistance: 500 megohms min.

Environmental:

Temperature Range: -25–125° C.

Temperature / Humidity Cycling: IEC 68-2-38; -20–80° C, 93% humidity, 3 hours, 5 cycles.

Vibration: MIL-STD-202, Method 201A; 10–55 Hz, 120 cycles, 1 minute / cycle.

Thermal Shock: -65–125° C, 30 minutes, 5 cycles.

Salt Spray: 35° C, 48 hours, 85% RH, 5% concentration.

Mechanical:

Mating Force: 7.0 N max.

Unmating Force: 9.0 N min.

Durability: 5,000 cycles.

Materials/Finishes:

Insulators: Teflon.

Inner Contacts: Beryllium Copper (female) or brass (male).

Springs: Stainless Steel.

Other Metal Parts: Brass.

Finish: Cable Connector bodies, nickel plated;
All other metal parts, gold plated.

*These specifications are typical and may not apply to all connectors. Detailed specifications for individual connectors are available on request.

Cable Plugs—Crimp Type for Flexible Cable

Figure 1
(Straight plug)

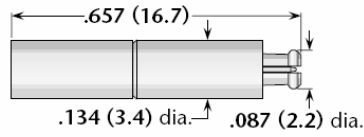
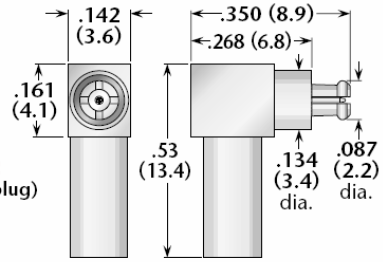

Figure 2
(Right angle plug)



Dimensions in inches (mm).

Cable Group	Figure	Plating		Delta P/N
		Body	Contact	
9	1	Nickel	Gold	8203-037-N000-500
11	1	Nickel	Gold	8203-038-N000-500
9	2	Nickel	Gold (C)	8207-037-N001-500
11	2	Nickel	Gold (C)	8207-038-N001-500
33	2	Nickel	Gold (C)	8207-405-N001-500

(C) in contact plating column indicates captive contact.

Cable Groups

9: RG-174, 179, 188, 187, 316; M17/94, 136, 172	11: RG-178, 196; M17/93	33: 1.13 mm miniature
---	-------------------------	-----------------------

Cable Assembly Procedure

Straight Plugs

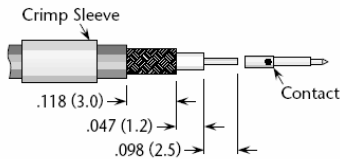

- 1) Trim cable per chart. Slide crimp sleeve back onto cable.

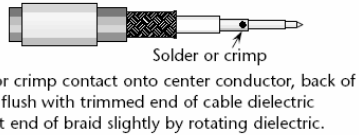

- 2) Solder or crimp contact onto center conductor, back of contact flush with trimmed end of cable dielectric. Flare cut end of braid slightly by rotating dielectric.

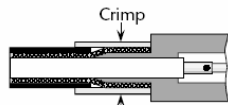

- 3) Insert cable/contact into rear of body, with all braid wires on outside of crimp tail. Push cable in until cable dielectric bottoms in connector. Slide crimp sleeve forward until flush with body and crimp.

Right Angle Plugs

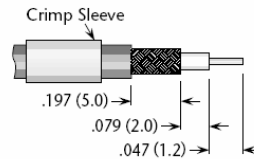

- 1) Trim cable per chart. Slide crimp sleeve back onto cable.

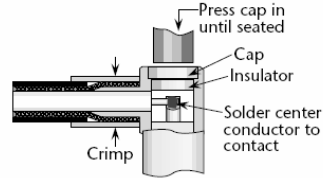

- 2) Flare cut end of braid slightly by rotating dielectric. Push cable into body assembly until trimmed end of cable dielectric is flush with cavity inside body assembly as shown. Slide crimp sleeve forward until flush with body and crimp.

Solder center conductor into notch in back of contact. Assemble insulator and cap, and press cap flush with body.

MC-Card Jack Switch—Edge-Card for SMT

Dimensions in inches (mm).

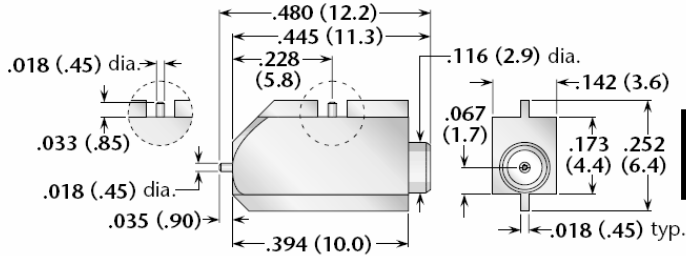

Packaging	Delta P/N
Individual	8271-000-G911-501
Tape & Reel (500)*	8271-000-G911-500

Circuit Diagram

Automatically switches signal from internal circuit to external circuit when mated.

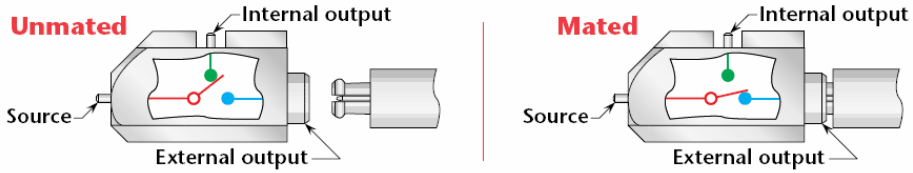

*Other reel quantities available (up to 1400 per reel) available. Contact factory for part numbers.
See next page for mounting and tape / reel information.

Right Angle PCB Jack Receptacle

Dimensions in inches (mm).

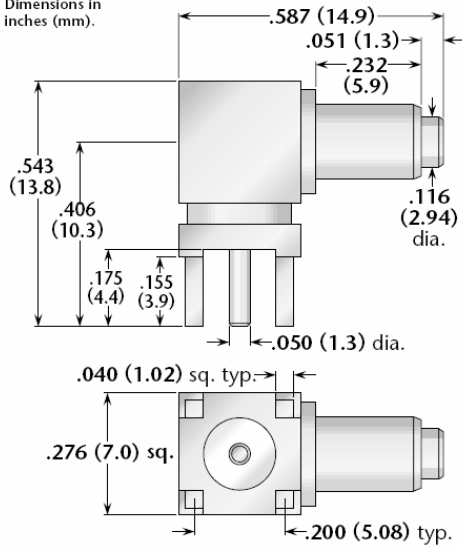

Delta P/N

8269-000-G001-500

See next page for mounting dimensions.

MC-Card Plug to SMA Jack Adapter

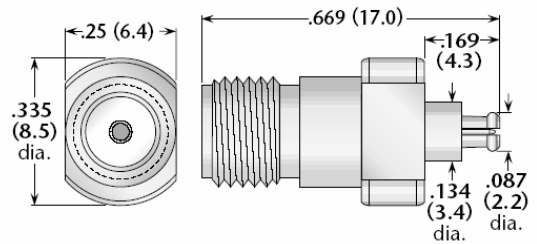

Delta P/N

2234-000-G001-504

Dimensions in inches (mm).

Electrical Performance—MC-Card Switching Connectors

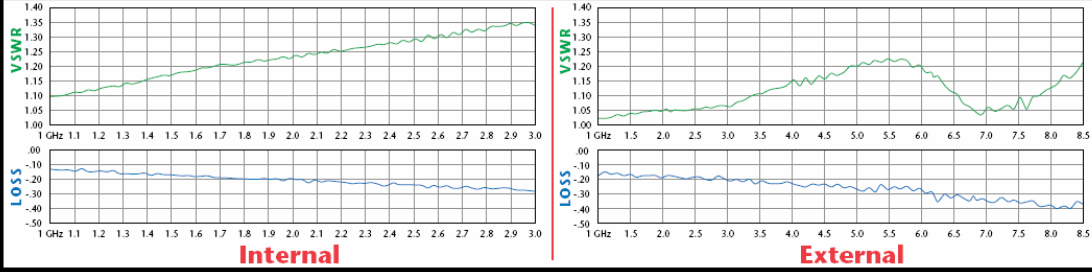

P.C.B. Mounting

Switching Receptacle

□ Solder Paste ■ P.C. Board

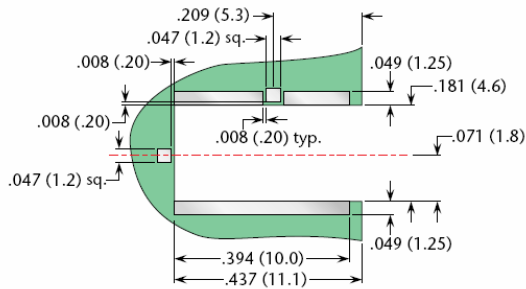

P.C. Board Receptacle

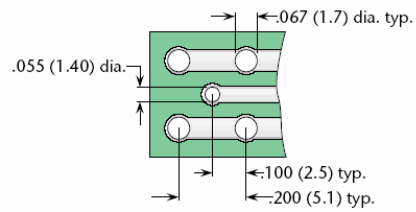

(PCB traces are shown for illustrative purpose only, and are not representative of actual circuitry.)

Dimensions in inches (mm).

Tape and Reel Packaging

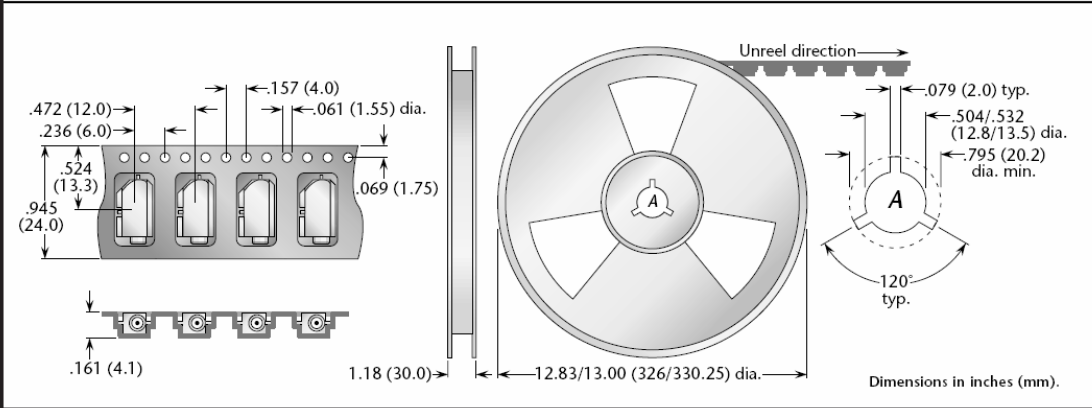

Dimensions in inches (mm).