

# SPECIFICATIONS

## ELECTRICAL

FREQUENCY: 0-2 GHZ  
 IMPEDANCE: 50 OHMS  
 VSWR: 1.2:1 MAX @ 2GHZ

## MECHANICAL

MATERIAL BODY: NICKEL PLATED BRASS  
 CONTACTS: BeCu  
 CONTACT PLATING: Au PER MIL-G-45204  
 INTERFACE: BNC: MIL-STD-348A  
 TEMPERATURE: -65° +125°C

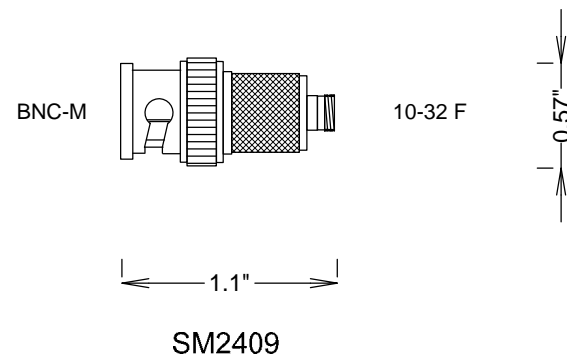
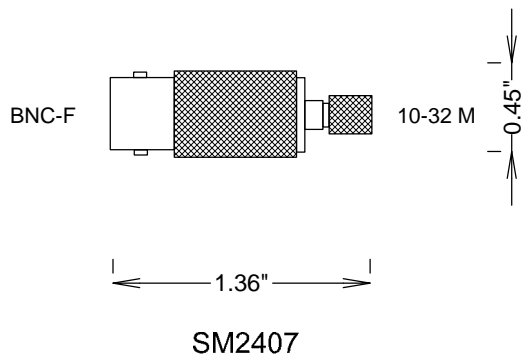

				<b>S. M. ELECTRONICS</b>	
				FAIRVIEW, TX 75069 WWW.SMELECTRONICS.US	
				TITLE	
				<b>10-32 / BNC ADAPTERS 2GHZ</b>	
SIZE	CAGE CODE	DWG NO	REV		
<b>A</b>	3FKR5	<b>SM2407, SM2409</b>	--		
SCALE			SHEET		