

SPECIFICATIONS

ELECTRICAL

FREQUENCY: 0-50 GHZ
 IMPEDANCE: 50 OHMS
 VSWR: 1.3:1 MAX

MECHANICAL

500 CYCLES MIN
 4 IN-OUNCES MIN CONTACT TORQUE
 8-10 IN-LBS COUPLING NUT MATING TORQUE
 DURABILITY: 500 CYCLES MIN.
 TEMPERATURE RANGE: -55 TO +100 DEG C

MATERIALS

BODY PASS STAINLESS STEEL
 CONTACTS Au PLATING

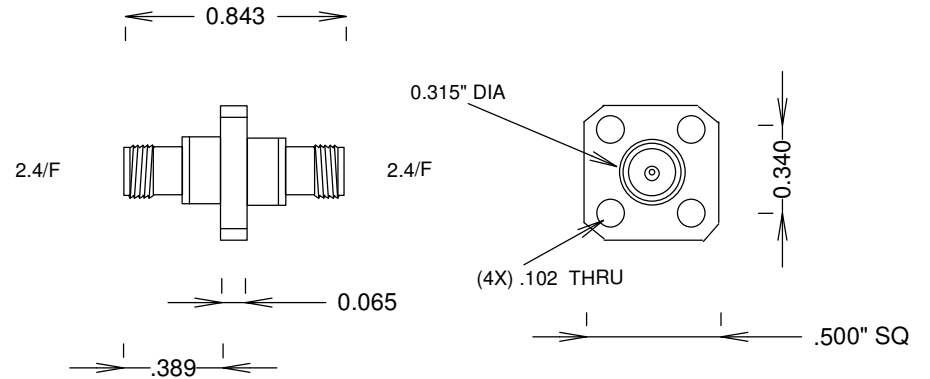

S. M. ELECTRONICS			
FAIRVIEW, TX WWW.SMELECTRONICS.US			
TITLE			
2.4-2.4mm F/F FLANGE ADAPTER			
SIZE	CAGE CODE	DWG NO	REV
A		SM3017	--
SCALE		SHEET	