

SPECIFICATIONS

ELECTRICAL

50 OHMS
 VSWR 1.33:1 MAX @ 40 GHZ
 FREQUENCY: 0-40 GHZ

MECHANICAL

500 CYCLES MIN
 8-10 LBS COUPLING NUT MATING TORQUE
 INTERFACE: MIL-STD-348A

ENVIRONMENTAL

-55°C TO +125°C
 CORROSION: MIL-STD 202
 VIBRATION: MIL-STD 202

MATERIALS PASSIVATED STAINLESS STEEL

BODY: SST ASTM A484 / A582
 CONTACTS: BeCu ATSM-B-196
 CONTACTS Au PLATED MIL-G-45204

1 X10-8 cc/sec He @ 1 ATMOSPHERE MAX

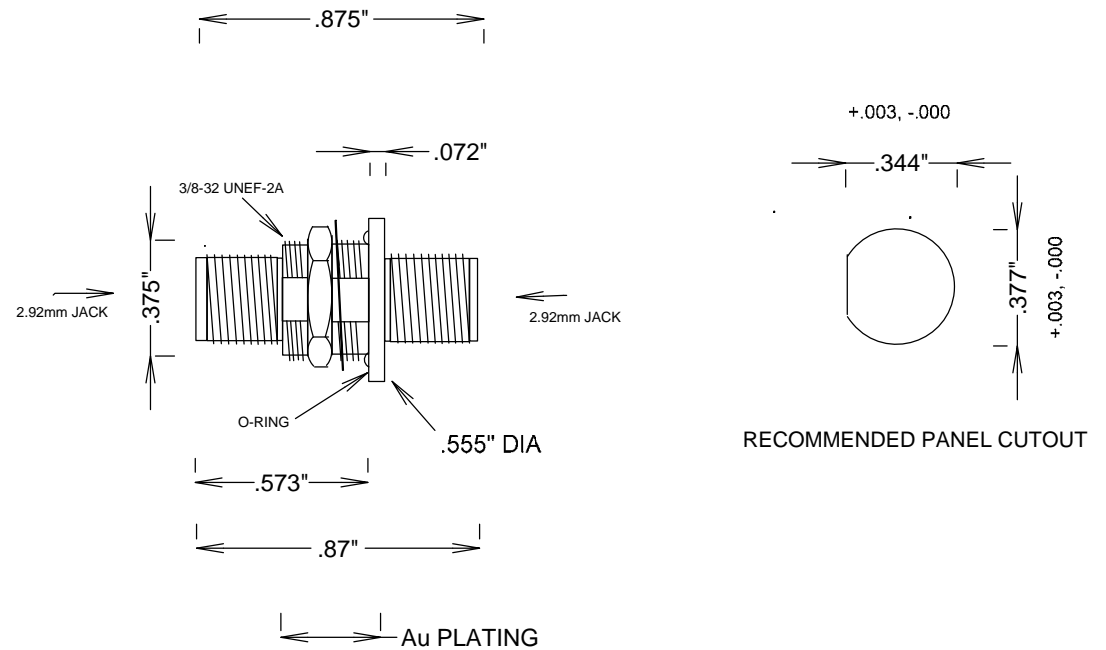

				S. M. ELECTRONICS L.L.C.			
				FAIRVIEW, TX 75069 WWW.SMELECTRONICS.US			
				TITLE			
				2.92mm F/F BULKHEAD HERMETIC ADAPTER			
SIZE		CAGE CODE		DWG NO		REV	
A		3FKR5		SM3224		--	
SCALE				SHEET			