

SPECIFICATIONS

ELECTRICAL

FREQUENCY: 0-18 GHZ
 IMPEDANCE: 50 OHMS
 VSWR 1.15:1 MAX
 (BMA GOOD TO 22GHZ;
 SMA MAY MODE ABOUT 20.5GHZ)

MECHANICAL

DURABILITY: 500 CYCLES MIN.
 TEMPERATURE RANGE: -65 TO +125 DEG C

MATERIALS

BODY PASS STAINLESS STEEL
 CONTACTS Au PLATING

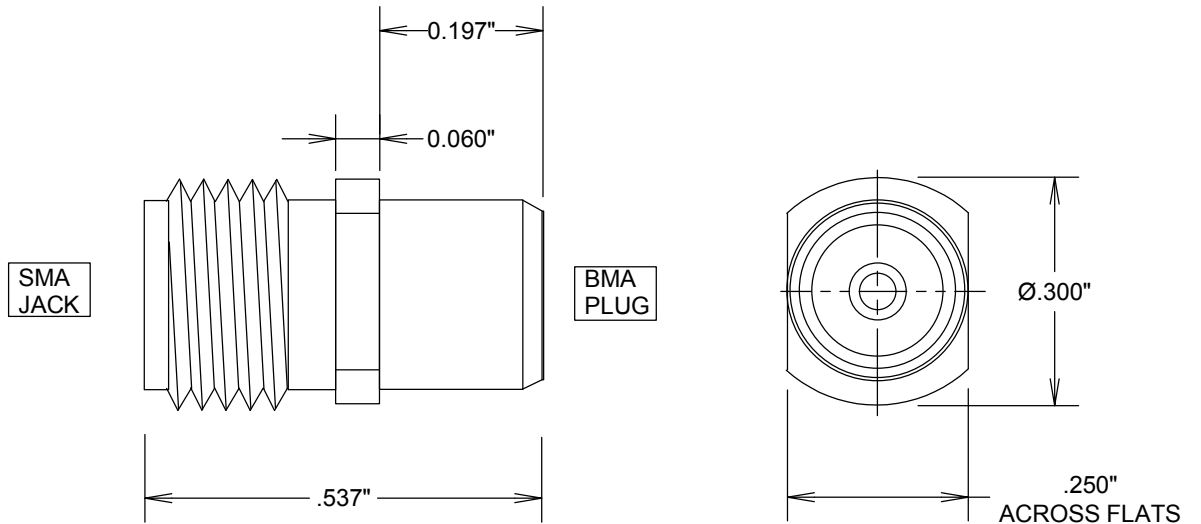

S. M. ELECTRONICS L.L.C

FAIRVIEW, TX WWW.SMELECTRONICSLLC.COM

TITLE

BMA (OSP) TO SMA ADAPTERS

SIZE	CAGE CODE	DWG NO	REV
A	3FKR5	SM3297	--

SCALE	SHEET
-------	-------