

SPECIFICATIONS

ELECTRICAL
 FREQUENCY: 0-4 GHZ
 IMPEDANCE: 50 OHMS

MECHANICAL
 MATERIAL BODY: NICKEL PLATED BRASS
 CONTACTS: BeCu (F), BRASS (M)
 CONTACT PLATING: PER MIL-G-45204
 Si PLATING 50μ" MIN
 INSULATOR: TEFLON

INTERFACE: MIL-STD-348A

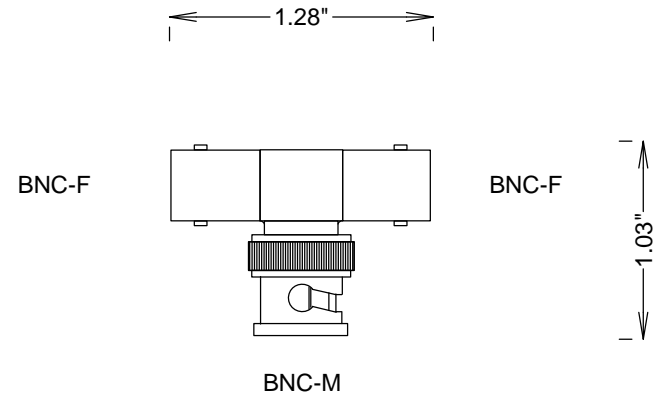

				S. M. ELECTRONICS			
				FAIRVIEW, TX WWW.SMELECTRONICS.US			
				TITLE			
				BNC T ADAPTER F-M-F 4GHZ			
SIZE		CAGE CODE		DWG NO		REV	
A		3FKR5		SM3448		-	
SCALE						SHEET	