

SPECIFICATIONS

ELECTRICAL

FREQUENCY: 0-8 GHZ
 IMPEDANCE: 50 OHMS
 VSWR: 1.25:1 MAX @ 8GHZ
 VRMS: 500 V SEA LEVEL

MECHANICAL

MATERIALS BODY TNC : PASSIVATED STAINLESS STEEL
 MATERIALS BODY BNC : NICKEL PLATED BRASS
 CONTACT PLATING: Au

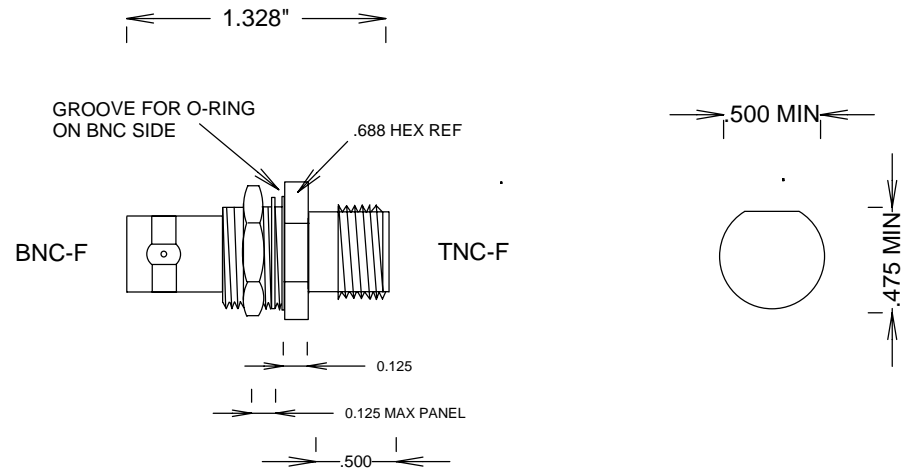

S. M. ELECTRONICS

FAIRVIEW, TX 75069 WWW.SMELECTRONICS.US

TITLE

TNC/F-BNC/F BULKHEAD 8GHZ ADAPTER

SIZE A	CAGE CODE 3FKR5	DWG NO SM3549	REV A
------------------	---------------------------	-------------------------	-----------------

SCALE	SHEET
-------	-------