

SPECIFICATIONS

ELECTRICAL

FREQUENCY: 0-12.4 GHZ
 IMPEDANCE: 50 OHMS
 VSWR: 1.25:1 MAX

MECHANICAL

MATERIALS BODY: NICKEL PLATED BRASS
 MATERIALS CONTACTS BeCu, Si PLATING
 INTERFACE: MIL-STD-348A

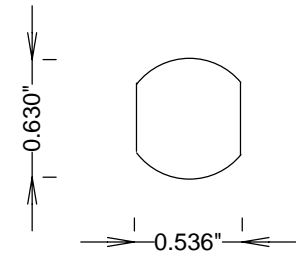
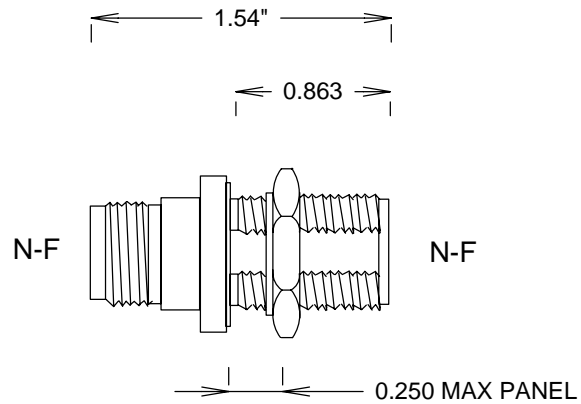

RECOMMENDED
 PANEL LAYOUT

| | | | | | | | |
|----------|--|--------------|--|---|--|-----|--|
| | | | | S. M. ELECTRONICS | | | |
| | | | | FAIRVIEW, TX WWW.SMELECTRONICS.US | | | |
| | | | | TITLE | | | |
| | | | | N-N F/F 12.4GHZ BULKHEAD ADAPTER | | | |
| SIZE | | CAGE CODE | | DWG NO | | REV | |
| A | | 3FKR5 | | SM4031 | | -- | |
| SCALE | | | | SHEET | | | |