

SPECIFICATIONS

ELECTRICAL

FREQUENCY: 0-18 GHZ
 IMPEDANCE: 50 OHMS
 VSWR: 1.15:1 MAX

MECHANICAL

MATERIALS BODY PASS STAINLESS STEEL
 MATERIALS CONTACTS BeCu Au PLATING
 INTERFACE: MIL-STD-348A
 DURABILITY: 500 CYCLES MIN

ENVIRONMENTAL

TEMP: -55 TO +125 DEG C

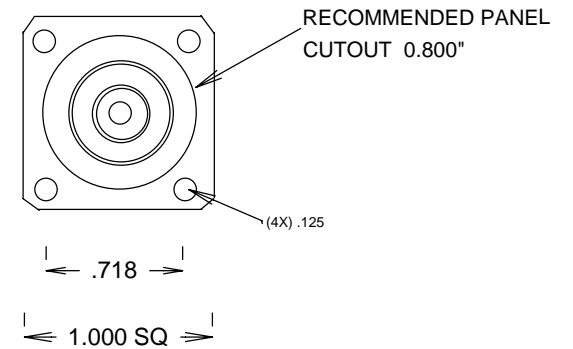
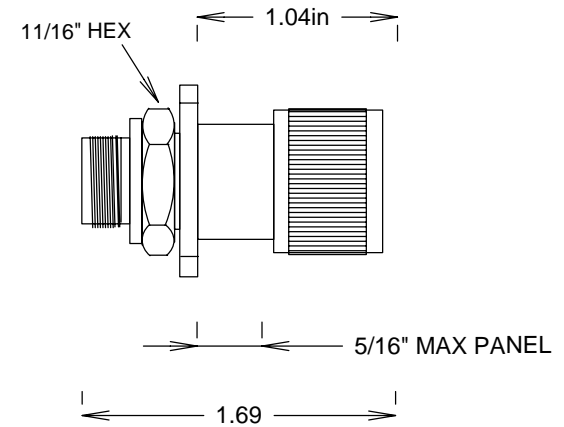

S. M. ELECTRONICS
 FAIRVIEW, TX 75069 WWW.SMELECTRONICS.US

TITLE
N-N M/F 18GHZ FLANGE ADAPTER

SIZE A	CAGE CODE 3FKR5	DWG NO SM4039	REV A
SCALE		SHEET	