

SPECIFICATIONS

ELECTRICAL

FREQUENCY: 0-12.4 GHZ
 IMPEDANCE: 75 OHMS
 VSWR: 6GHZ 1.2:1 MAX
 VSWR 12.4GHZ: 1.4:1 MAX
 ISOLATED GROUND

MECHANICAL

MATERIALS BODY NICKEL PLATED BRASS
 CONTACT: BeCu
 CONTACT PLATING: Au MIL-G-45204
 MATERIAL INSULATOR: TEFLON
 INTERFACE: MIL-STD-348A

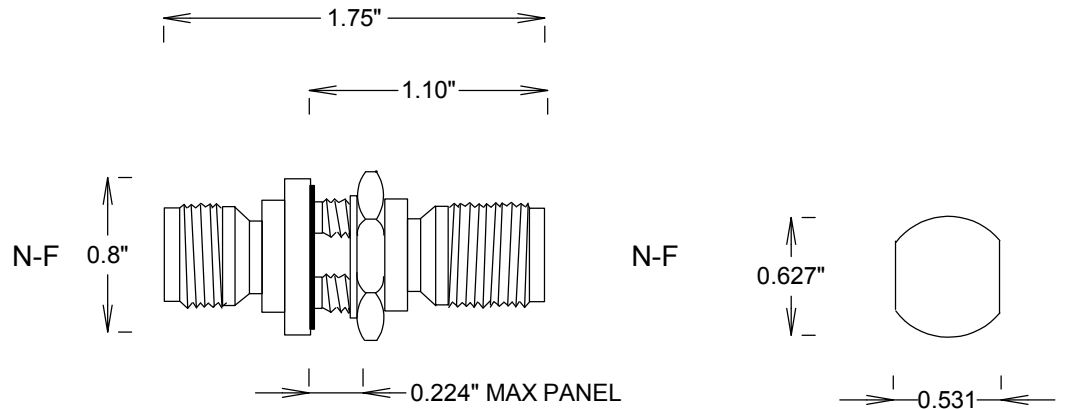

SM4029

RECOMMENDED
 PANEL LAYOUT

				S. M. ELECTRONICS L.L.C			
				FAIRVIEW, TX WWW.SMELECTRONICSLLC.COM			
				TITLE			
				N-N F/F 12GHZ BULKHEAD ISOLATED GROUND			
SIZE		CAGE CODE		DWG NO		REV	
A		3FKR5		SM4051		--	
SCALE						SHEET	