

SPECIFICATIONS

ELECTRICAL

FREQUENCY: 0-11 GHZ
 IMPEDANCE: 50 OHMS
 VSWR: 1.25:1 MAX

MECHANICAL

MATERIALS BODY Ni PLATED BRASS
 MATERIALS CONTACTS BeCu Au PLATING
 DURABILITY: 500 CYCLES MIN

ENVIRONMENTAL

CORROSION MIL-STD-202
 VIBRATION MIL-STD-202
 SHOCK MIL-STD-202

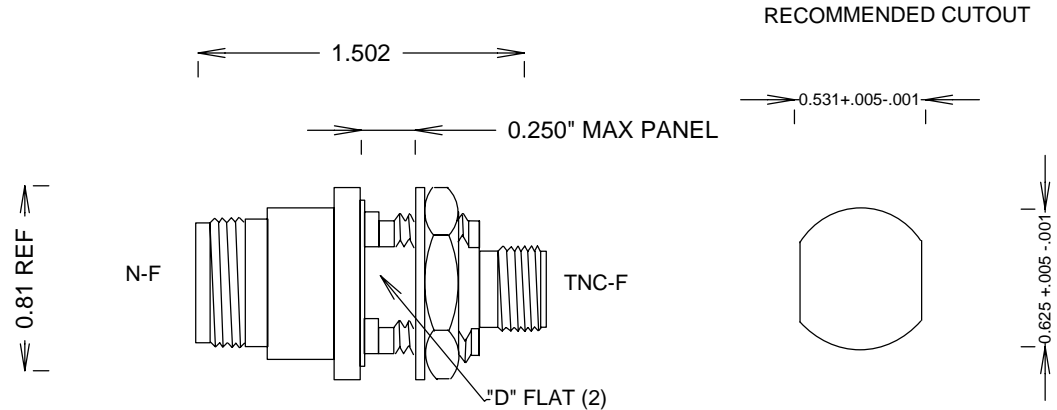

				S. M. ELECTRONICS	
				FAIRVIEW, TX 75069 WWW.SMELECTRONICS.US	
				TITLE	
				TNC/F-N/F 11GHZ BULKHEAD ADAPTER	
SIZE	CAGE CODE	DWG NO	SM4149		
A	3FKR5				
SCALE			SHEET		
			REV B		