

SPECIFICATIONS

ELECTRICAL

FREQUENCY: 0-12.4GHZ
 IMPEDANCE: 50 OHMS
 VSWR: 1.15:1 MAX @ 8GHZ
 VSWR: 1.2:1 MAX @ 12.4 GHZ
 VSWR: 1.35:1 MAX @ 18 GHZ
 VRMS: 500 V SEA LEVEL

MECHANICAL

MATERIALS BODY: TRIMETAL PLATED BRASS
 MATERIALS CONTACTS: AU PLATING
 DIELECTRIC: TEFLON
 INTERFACE: MIL-STD-348A
 DURABILITY: 100 CYCLES MIN

ENVIRONMENTAL

-65 TO +165 DEG C

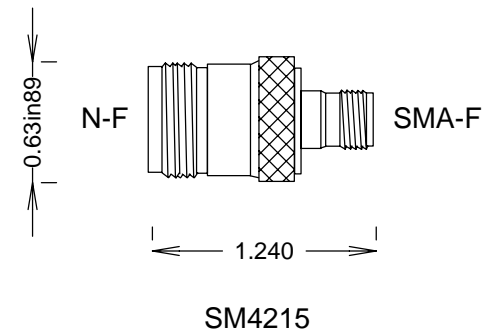
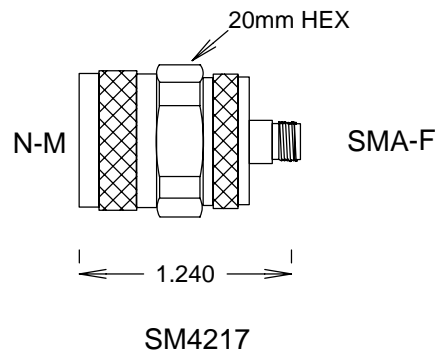
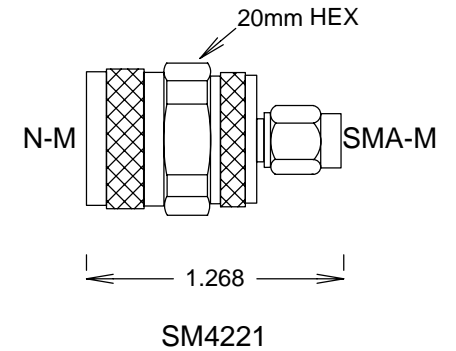
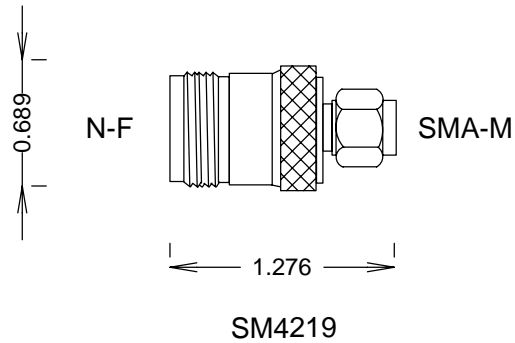

S. M. ELECTRONICS

FAIRVIEW, TX WWW.SMELECTRONICS.US

TITLE

SMA-N ADAPTERS BRASS

SIZE	CAGE CODE	DWG NO	REV
A	3FKR5	SM4215, SM4217, SM4219, SM4221	A
SCALE			SHEET