

SPECIFICATIONS

ELECTRICAL

FREQUENCY: 0-8 GHZ
 IMPEDANCE: 50 OHMS
 VSWR: 1.2:1 MAX

MECHANICAL

MATERIALS BODY NICKEL PLATED BRASS
 MATERIALS CONTACTS BeCu Au PLATING
 INSULATOR: TEFLON
 INTERFACE: MIL-STD-348A
 DURABILITY: 100 CYCLES MIN

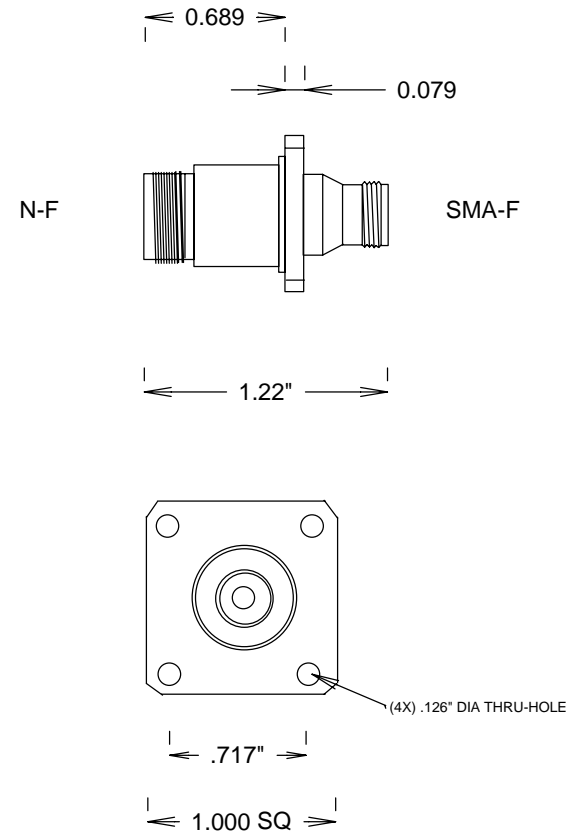

				S. M. ELECTRONICS	
				FAIRVIEW, TX WWW.SMELECTRONICS.US	
				TITLE	
				N-SMA F/F 8GHZ FLANGE ADAPTER	
SIZE		CAGE CODE		DWG NO	
A		3FKR5		SM4228	
				REV	
				--	
				SHEET	