

SPECIFICATIONS

ELECTRICAL

FREQUENCY: 0-18 GHZ
 IMPEDANCE: 50 OHMS
 VSWR: 1.15:1 MAX @ 18 GHZ
 VRMS: 500 V SEA LEVEL

MECHANICAL

MATERIALS BODY: PASSIVATED S STEEL
 MATERIALS CONTACTS: AU PLATING
 INTERFACE: MIL-STD-348

DURABILITY: 500 CYCLES MIN

ENVIRONMENTAL

-65 TO +165 DEG C
 CORROSION MIL-STD-202
 VIBRATION MIL-STD-202
 SHOCK MIL-STD-202

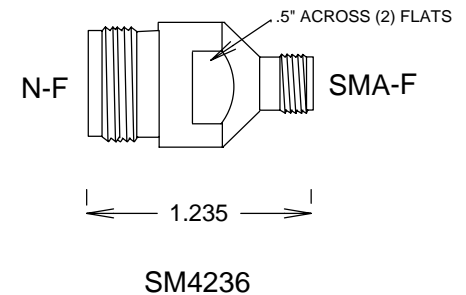
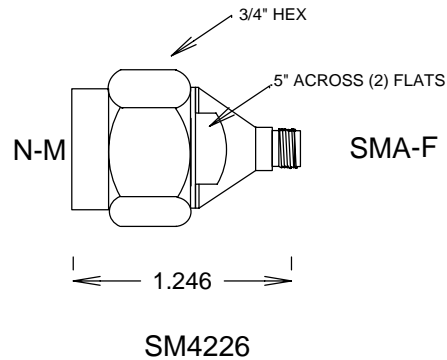
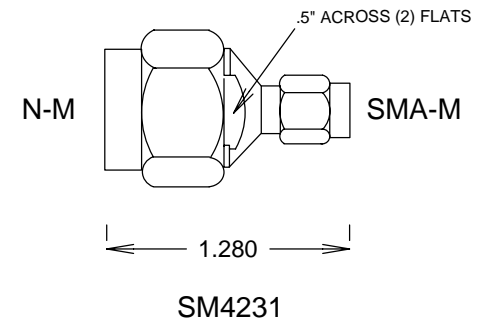
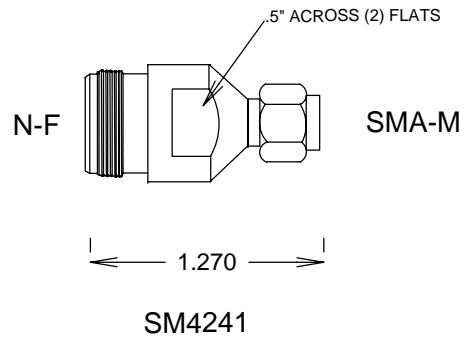

				S. M. ELECTRONICS			
				FAIRVIEW, TX WWW.SMELECTRONICS.US			
				TITLE			
				SMA-N ADAPTERS S STEEL 18GHZ			
SIZE		CAGE CODE		DWG NO		REV	
A		3FKR5		SM4226, SM4231, SM4236, SM4241		B	
SCALE						SHEET	