

# SPECIFICATIONS

## ELECTRICAL

FREQUENCY: 0-18 GHZ  
 IMPEDANCE: 50 OHMS  
 VSWR: 1.20:1 MAX  
 VRMS: 250 V SEA LEVEL

## MECHANICAL

MATERIALS BODY PASS STAINLESS STEEL  
 MATERIALS CONTACTS BeCu Au PLATING  
 CONTACT CAPTIVATION: 6LBS MIN AXIAL FORCE  
 INSULATOR: TEFLON  
 INTERFACE: MIL-STD-348A  
 DURABILITY: 500 CYCLES MIN

## ENVIRONMENTAL

CORROSION MIL-STD-202  
 VIBRATION MIL-STD-202  
 SHOCK MIL-STD-202

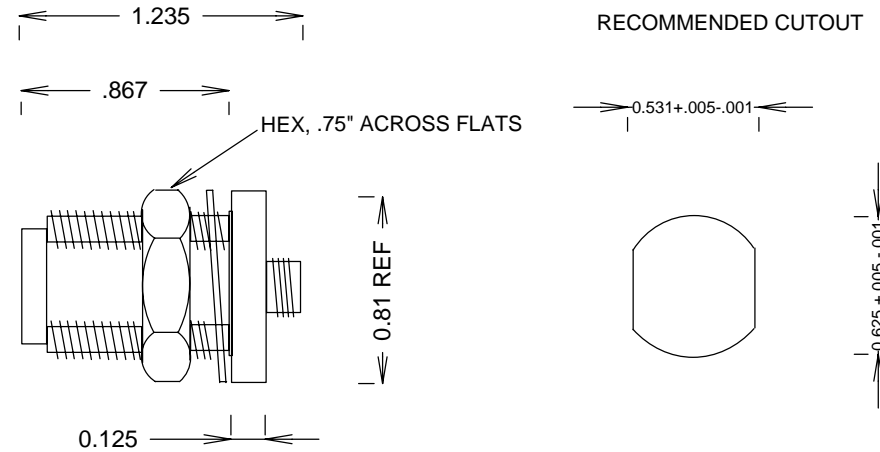

COMES WITH GASKET FOR SEALING

|          |  |           |  |   |  |          |  |
|----------|--|-----------|--|---|--|----------|--|
|          |  |           |  | <b>S. M. ELECTRONICS</b>                |  |          |  |
|          |  |           |  | FAIRVIEW, TX 75069 WWW.SMELECTRONICS.US |  |          |  |
|          |  |           |  | TITLE                                   |  |          |  |
|          |  |           |  | <b>SMA/F-N/F 18GHZ BULKHEAD ADAPTER</b> |  |          |  |
| SIZE     |  | CAGE CODE |  | DWG NO                                  |  | REV      |  |
| <b>A</b> |  | 3FKR5     |  | <b>SM4237</b>                           |  | <b>C</b> |  |
| SCALE    |  |           |  |   |  | SHEET    |  |