

# SPECIFICATIONS

## ELECTRICAL

FREQUENCY: 0-6 GHZ  
 IMPEDANCE: 50 OHMS  
 VSWR: 1.20:1  
 OP TEMP: -45 TO 80 DEG C

## MECHANICAL

MATERIALS BODY: TRIMETAL PLATED BRASS  
 MATERIALS CONTACTS Au PLATING  
 DURABILITY: 100 CYCLES MIN

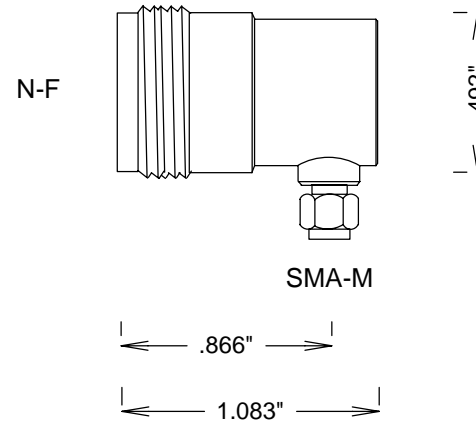

**S. M. ELECTRONICS**

FAIRVIEW, TX WWW.SMELECTRONICS.US

TITLE

**N/F-SMA/M RIGHT ANGLE ADAPTER**

SIZE	CAGE CODE	DWG NO	REV
A	3FKR5	SM4243	--
SCALE		SHEET	