

SPECIFICATIONS

ELECTRICAL
 FREQUENCY: 0-11 GHZ
 IMPEDANCE: 50 OHMS
 VSWR: 1.20:1 MAX

MECHANICAL
 MATERIALS BODY : NICKEL PLATED BRASS
 MATERIALS CONTACTS BeCu Au PLATING
 DURABILITY: 100 CYCLES MIN
 INTERFACE: MIL-STD-348A

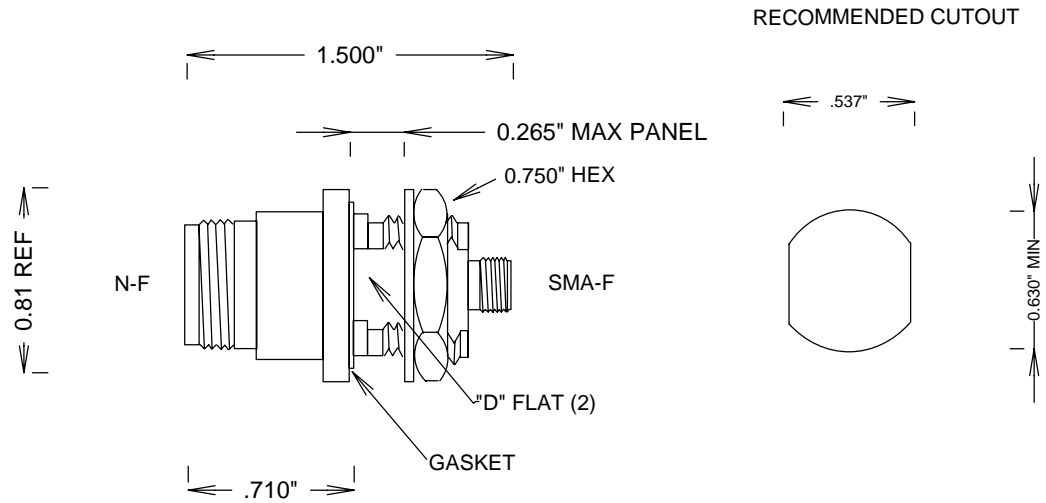

				S. M. ELECTRONICS	
				FAIRVIEW TX 75069 WWW.SMELECTRONICS.US	
				TITLE	
				SMA/F-N/F 11GHZ BULKHEAD ADAPTER	
		SIZE	CAGE CODE	DWG NO	REV
		A	3FKR5	SM4247	B
				SCALE	SHEET