

SPECIFICATIONS

ELECTRICAL

FREQUENCY: 0-4 GHZ
 IMPEDANCE: 50 OHMS
 VSWR: 1.2:1 MAX

MECHANICAL

MATERIALS BODY: NICKEL PLATED BRASS
 MATERIALS CONTACTS BeCu(F), BRASS(M)
 CONTACT PLATING: Au PER MIL-G-45204
 INSULATOR: TEFLON
 RECOMMENDED TORQUE 7-16 221 IN-LBS
 DURABILITY: 500 CYCLES MIN

OPERATING TEMP: -55° TO +120° C

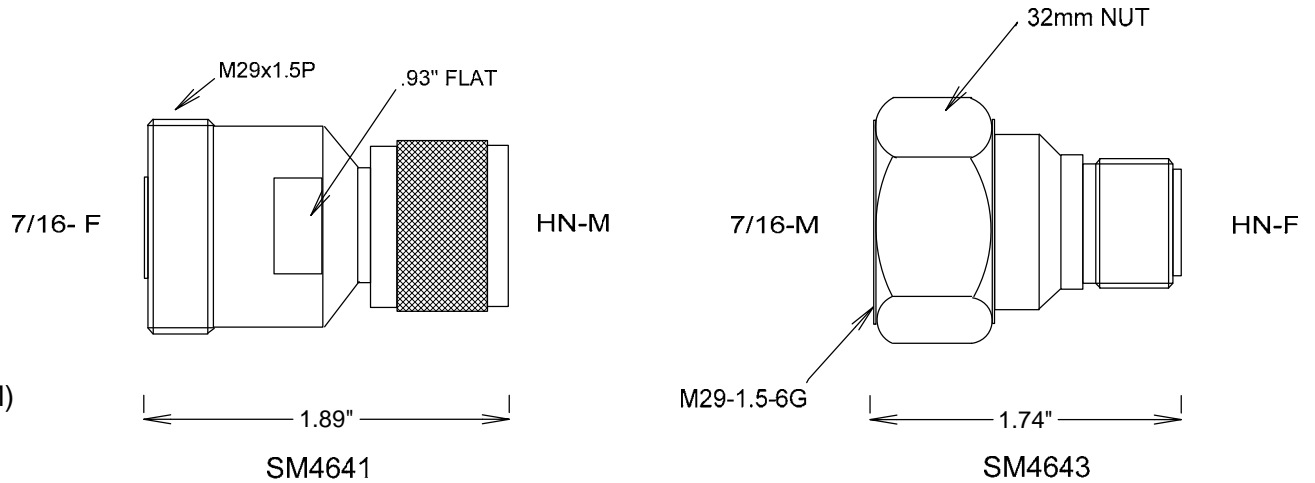

				S. M. ELECTRONICS L.L.C.			
				FAIRVIEW, TX WWW.SMELECTRONICS.US			
				TITLE			
				HN - 7/16 ADAPTERS			
SIZE	CAGE CODE	DWG NO		REV			
A	3FKR5	SM4641, SM4643		--			
SCALE			SHEET				