

SPECIFICATIONS

ELECTRICAL

FREQUENCY: 0-4 GHZ
 IMPEDANCE: 50 OHMS
 VSWR: 1.25:1 MAX
 PIM; 160dbc typ for 2 carriers @ 20W

MECHANICAL

MATERIALS BODY: TRIMETAL PLATED BRASS
 MATERIALS CONTACTS SI PLATING
 RECOMMENDED TORQUE 7-16 221 IN-LBS
 DURABILITY: 500 CYCLES MIN

OPERATING TEMP: -45 TO +80 DEG C

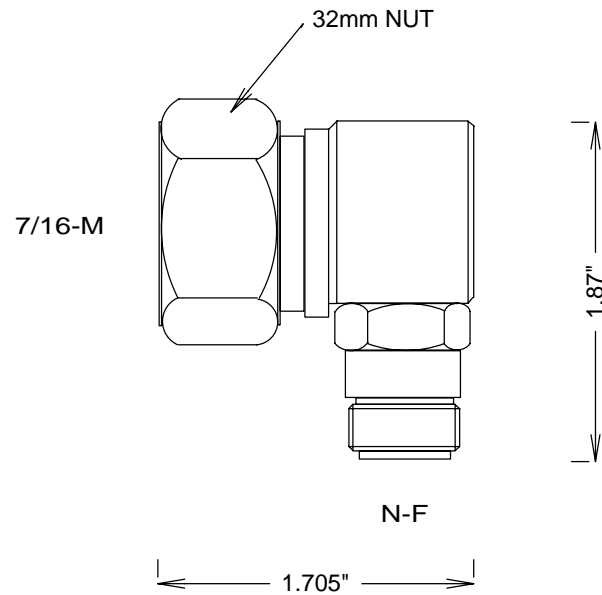

				S. M. ELECTRONICS	
				FAIRVIEW, TX WWW.SMELECTRONICS.US	
				TITLE	
				N - 7/16 RIGHT ANGLE ADAPTER	
SIZE		CAGE CODE	DWG NO		REV
A		3FKR5	SM4683		--
SCALE					SHEET