

SPECIFICATIONS

ELECTRICAL

FREQUENCY: 0-6 GHZ
 IMPEDANCE: 50 OHMS
 VSWR: 1.25:1

MECHANICAL

MATERIALS 7/16 BODY: TRIMETAL PLATED BRASS
 MATERIALS SMA BODY: PASSIVATED STAINLESS STEEL
 MATERIALS CONTACTS Au PLATING
 RECOMMENDED TORQUE 7-16 221 IN-LBS; SMA 7-9 IN-LBS
 DURABILITY: 500 CYCLES MIN

ENVIRONMENTAL PER DIN 47223
 OPERATING TEMP: -45 TO +85 DEG C

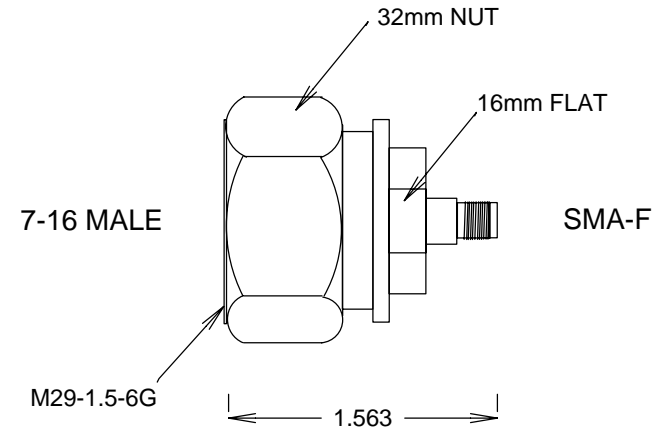

SM4693

				S. M. ELECTRONICS			
				FAIRVIEW, TX WWW.SMELECTRONICS.US			
				TITLE			
				SMA(F)- 7/16(M) DIN ADAPTER			
SIZE		CAGE CODE		DWG NO		REV	
A				SM4693		--	
SCALE						SHEET	