

SPECIFICATIONS

ELECTRICAL

FREQUENCY: 0-18 GHZ
 IMPEDANCE: 50 OHMS
 VSWR: 1.25:1 MAX

MECHANICAL

MATERIALS BODY PASS STAINLESS STEEL
 MATERIALS CONTACTS BeCu
 CONTACT PLATING: Au MIL-G-45204
 INSULATOR: TEFLON ASTM
 DURABILITY: 500 CYCLES MIN
 INTERFACE: MIL-STD-348A

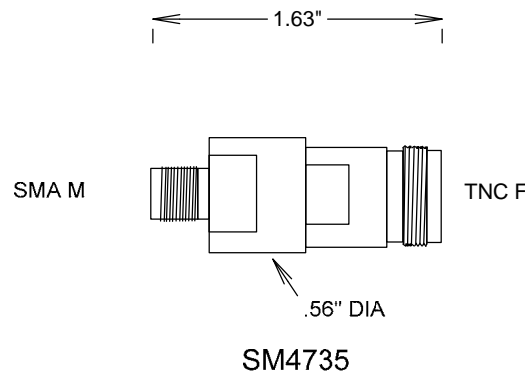

SM4735

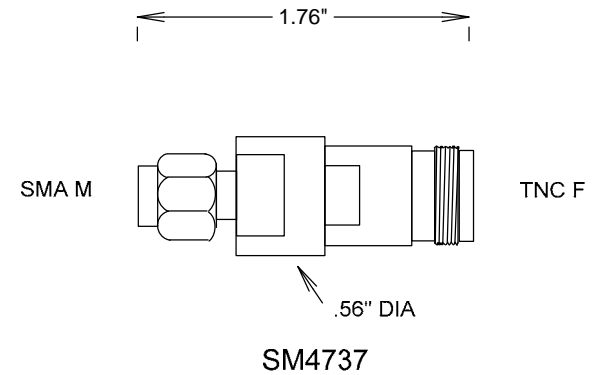

SM4737

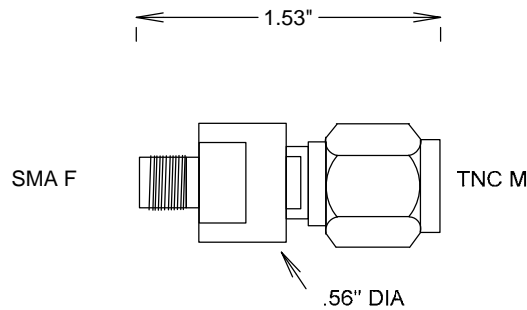

SM4736

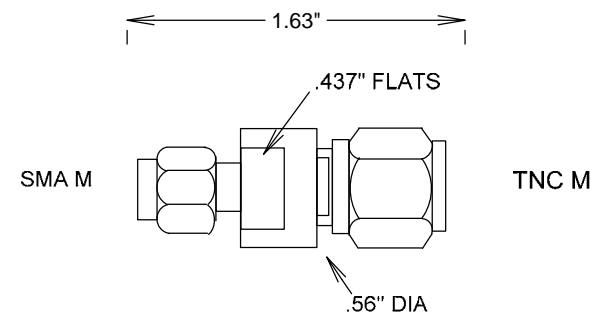

SM4738

S. M. ELECTRONICS

FAIRVIEW, TX WWW.SMELECTRONICS.US

TITLE

SMA-TNC 18GHZ ADAPTERS

SIZE	CAGE CODE	DWG NO	REV
A	3FKR5	SM4735, 4736, 4737, 4738	--

SCALE

SHEET