

SPECIFICATIONS

ELECTRICAL

FREQUENCY: 0-18 GHZ
 IMPEDANCE: 50 OHMS
 VSWR 1.15 MAX

MECHANICAL

MATERIALS BODY PASSIVATED S. STEEL
 MATERIALS CONTACTS BeCu Au PLATING
 DURABILITY: 500 CYCLES MIN

ENVIRONMENTAL

CORROSION MIL-STD-202
 VIBRATION MIL-STD-202
 SHOCK MIL-STD-202

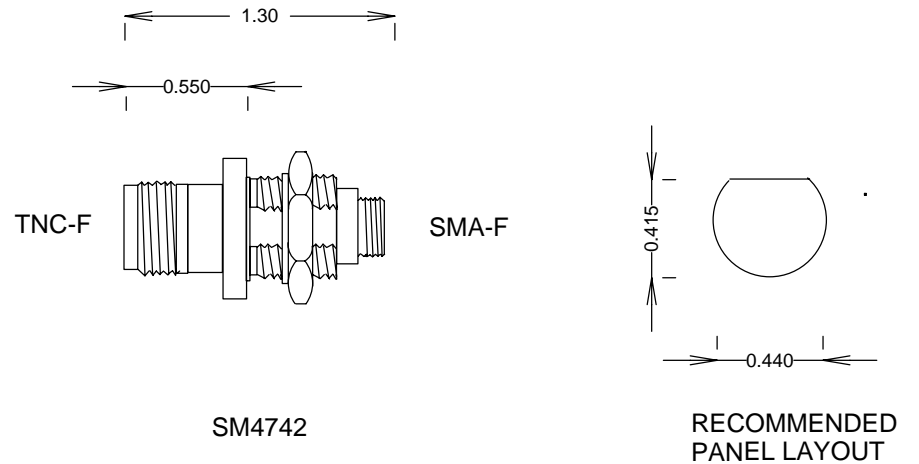

S. M. ELECTRONICS

FAIRVIEW, TX WWW.SMELECTRONICS.US

TITLE

SMA/F-TNC/F BULKHEAD ADAPTER 18GHZ

SIZE	CAGE CODE	DWG NO	REV
A	3FKR5	SM4742	-

SCALE	SHEET
-------	-------