

SPECIFICATIONS

ELECTRICAL

FREQUENCY: 0-11 GHZ
 IMPEDANCE: 50 OHMS

MECHANICAL

MATERIALS SMA BODY PASSIVATED S. STEEL
 MATERIALS TNC BODY Ni PLATED BRASS
 MATERIALS CONTACTS BeCu Au PLATING
 DURABILITY: 500 CYCLES MIN

ENVIRONMENTAL

CORROSION MIL-STD-202
 VIBRATION MIL-STD-202
 SHOCK MIL-STD-202

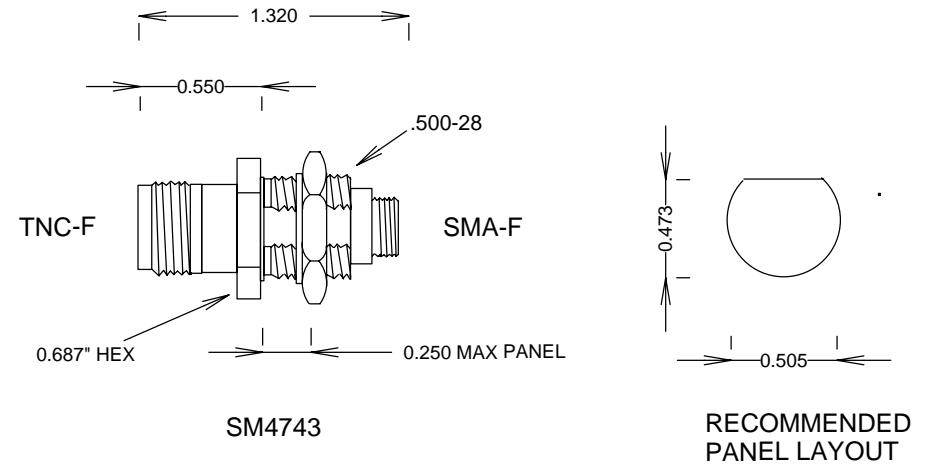

| | | | | | |
|--|--|----------|--------------|---|----------|
| | | | | S. M. ELECTRONICS | |
| | | | | FAIRVIEW, TX WWW.SMELECTRONICS.US | |
| | | | | TITLE | |
| | | | | SMA/F-TNC/F BULKHEAD ADAPTER | |
| | | SIZE | CAGE CODE | DWG NO | REV |
| | | A | 3FKR5 | SM4743 | C |
| | | | | SCALE | SHEET |