

# SPECIFICATIONS

## ELECTRICAL

FREQUENCY: 0-12.4 GHZ  
 VSWR: 1.25:1 MAX  
 IMPEDANCE: 50 OHMS

## MECHANICAL

MATERIALS BODY PASSIVATED S. STEEL  
 MATERIALS CONTACTS BeCu  
 CONTACT PLATING: Au MIL-G-45204  
 INTERFACE: MIL-STD-348B  
 INSULATOR: TEFLON  
 DURABILITY: 500 CYCLES MIN  
 TEMPERATURE: -55 TO +125° C  
 ROHS COMPLIANT

## HERMETIC

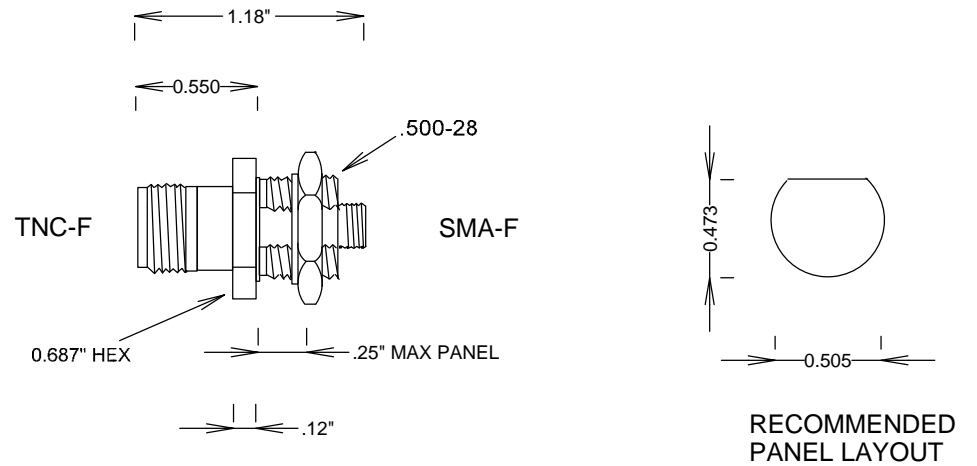

**S. M. ELECTRONICS L.L.C.**

FAIRVIEW, TX WWW.SMELECTRONICS.US

TITLE

**SMA/F-TNC/F BULKHEAD ADAPTER HERMETIC**

SIZE	CAGE CODE	DWG NO	REV
<b>A</b>	<b>3FKR5</b>	<b>SM4745</b>	--

SCALE	SHEET
-------	-------