

# SPECIFICATIONS

## ELECTRICAL

FREQUENCY: 0-11 GHZ  
 IMPEDANCE: 50 OHMS  
 VSWR: 1.25:1 MAX  
 VRMS: 250 V SEA LEVEL

## MECHANICAL

MATERIALS BODIES: NICKEL PLATED BRASS  
 CONTACT PLATING: Au  
 DIELECTRIC: TFE FLUOROCARBON

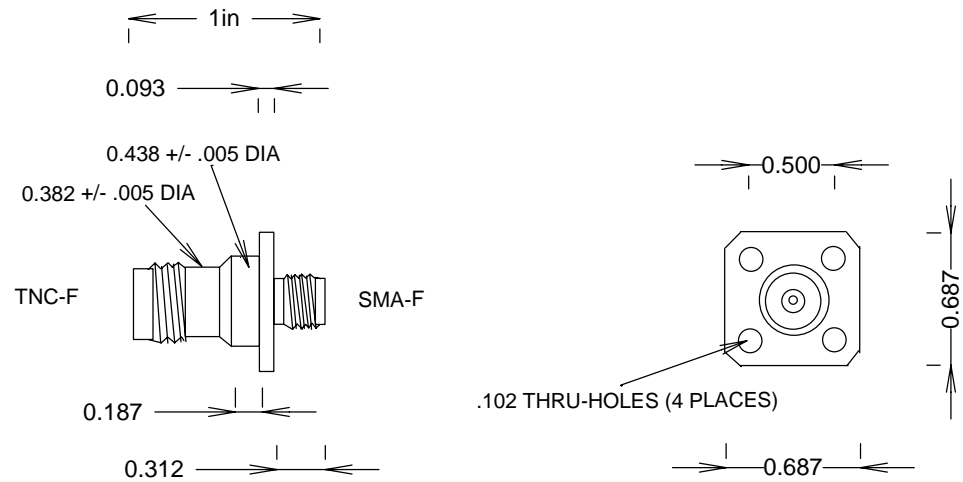

				<b>S. M. ELECTRONICS</b>	
				FAIRVIEW, TX <a href="http://WWW.SMELECTRONICS.US">WWW.SMELECTRONICS.US</a>	
				TITLE	
				<b>SMA/F-TNC/F FLANGE 11GHZ ADAPTER</b>	
SIZE		CAGE CODE		DWG NO	
<b>A</b>		<b>3FKR5</b>		<b>SM4756</b>	
SCALE				SHEET	
				REV --	