

# SPECIFICATIONS

## ELECTRICAL

FREQUENCY: 0-18 GHZ  
 IMPEDANCE: 50 OHMS  
 VSWR: 1.15:1 MAX

## MECHANICAL

MATERIALS BODY PASS STAINLESS STEEL  
 MATERIALS CONTACTS BeCu  
 CONTACT PLATING: Au PER MIL-G-45204  
 INSULATOR: TEFLON  
 INTERFACE: MIL-STD-348B  
 DURABILITY: 500 CYCLES MIN

## ENVIRONMENTAL

CORROSION MIL-STD-202  
 VIBRATION MIL-STD-202  
 SHOCK MIL-STD-202  
 ROHS COMPLIANT

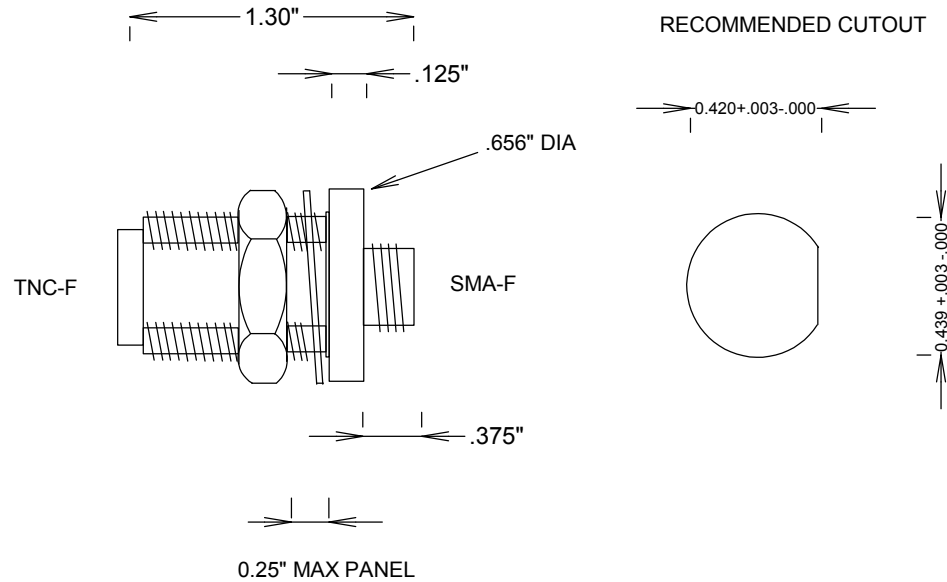

				<b>S. M. ELECTRONICS L.L.C.</b>			
				FAIRVIEW, TX WWW.SMELECTRONICS.US			
				TITLE			
				SMA/F-TNC/F 18GHZ BULKHEAD ADAPT.			
SIZE	CAGE CODE	DWG NO		REV			
<b>A</b>		<b>SM4759</b>		<b>A</b>			
SCALE			SHEET				