

SPECIFICATIONS

ELECTRICAL

FREQUENCY: 0-11 GHZ
 IMPEDANCE: 50 OHMS
 VSWR: 1.25:1 MAX @ 11GHZ

MECHANICAL

MATERIAL TNC BODY: NICKLE PLATED BRASS
 MATERIAL SMA BODY: PASSIVATED S STEEL
 MATERIALS CONTACTS MALE BRASS; FEMALE BeCu
 PLATING CONTACTS: Au MIL-G-45204
 DURABILITY: 500 CYCLES MIN
 INSULATOR: TEFLON
 INTERFACE: MIL-STD-348A
 TEMPERASTURE: -55 TO +125° C
 ROHS COMPLIANT

TNC MALE
 QUICK RELEASE

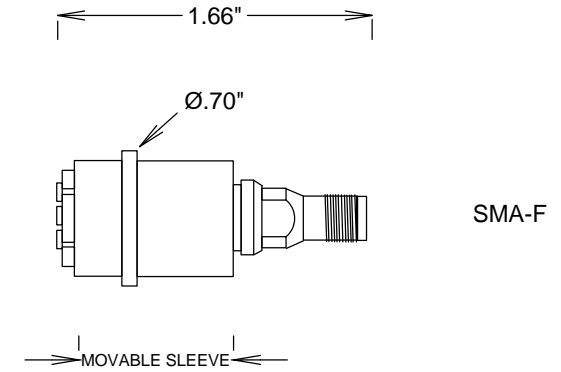

TNC-MALE QUICK RELEASE
 TO ATTACH, SLIDE SM4793 OVER TNC FEMALE,
 THEN MOVE SLEEVE OVER TNC FEMALE.
 TO RELEASE, MOVE SLEEVE OTHER WAY

				S. M. ELECTRONICS L.L.C.	
				FAIRVIEW, TX WWW.SMELECTRONICS.US	
				TITLE	
				SMA/F-TNC/M/QR ADAPTER	
		SIZE	CAGE CODE	DWG NO	REV
		A		SM4769	--
			SCALE	SHEET	