

SPECIFICATIONS

ELECTRICAL

FREQUENCY: 0-18 GHZ
 IMPEDANCE: 50 OHMS
 VSWR: 1.20:1 MAX

MECHANICAL

MATERIALS BODY PASS. STAINLESS STEEL
 MATERIALS CONTACTS Au PLATING
 DURABILITY: 500 CYCLES MIN

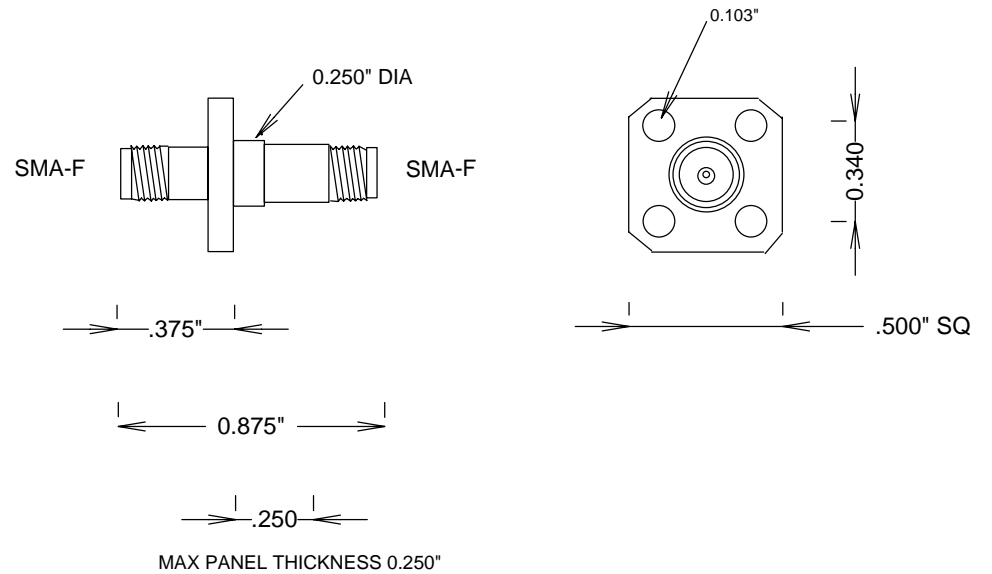

				S. M. ELECTRONICS	
				FAIRVIEW, TX WWW.SMELECTRONICS.US	
				TITLE	
				SMA - SMA FLANGE ADAPTER	
SIZE	CAGE CODE	DWG NO	SM4959		
A	3FKR5				
SCALE			SHEET		REV A