

# SPECIFICATIONS

## ELECTRICAL

FREQUENCY: 0-18 GHZ  
 IMPEDANCE: 50 OHMS  
 VSWR: 1.20:1 MAX

## MECHANICAL

MATERIALS BODY PASS. STAINLESS STEEL  
 MATERIALS CONTACTS Au PLATING  
 DURABILITY: 500 CYCLES MIN

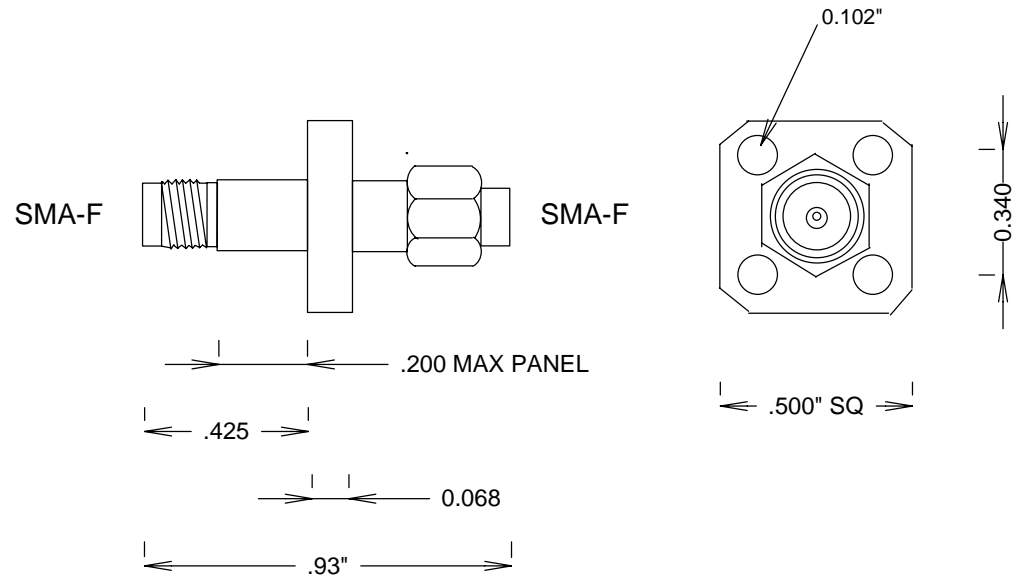

				<b>S. M. ELECTRONICS</b>	
				FAIRVIEW, TX WWW.SMELECTRONICS.US	
				TITLE	
				<b>SMA/M - SMA/F FLANGE ADAPTER</b>	
SIZE	CAGE CODE	DWG NO			
<b>A</b>	<b>3FKR5</b>	<b>SM4968</b>			
SCALE		SHEET		REV	A