

# SPECIFICATIONS

**ELECTRICAL**  
 50 OHMS  
 VSWR 1.25:1 MAX @ 18 GHZ  
 FREQUENCY: 0-18 GHZ

**MECHANICAL**  
 500 CYCLES MIN  
 INTERFACE: MIL-STD-348A

**MATERIALS**  
 BODY AU PLATED STAINLESS STEEL  
 CENTER CONTACTS BECU(f), BRASS(m)  
 CONTACT PLATING: Au MIL-G-45204  
 DIELECTRIC: TEFLON  
 ROHS COMPLIANT

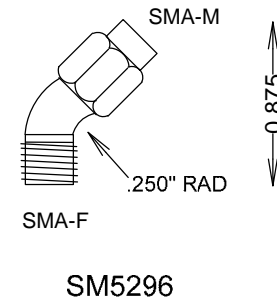
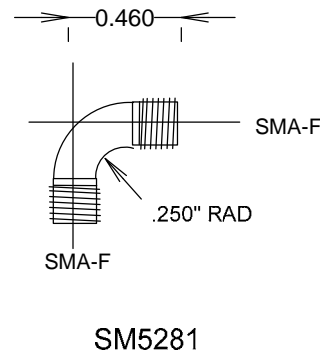
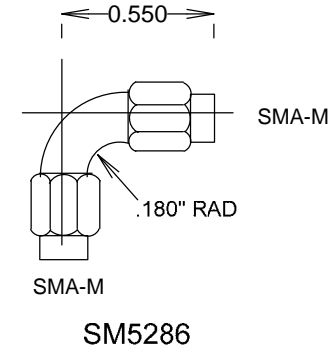
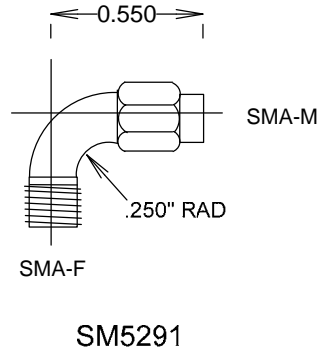

**S. M. ELECTRONICS L.L.C.**  
 FAIRVIEW, TEXAS WWW.SMELECTRONICS.US

TITLE  
**SMA-SMA SWEPT ADAPTERS**

SIZE <b>A</b>	CAGE CODE <b>3FKR5</b>	DWG NO <b>SM5281 - SM5296</b>	REV <b>D</b>
SCALE		SHEET	