

# SPECIFICATIONS

## ELECTRICAL

FREQUENCY: 0-11 GHZ  
 IMPEDANCE: 50 OHMS  
 VSWR: 1.25:1 MAX

## MECHANICAL

MATERIALS BODY : SILVER  
 CONTACTS: BeCu, Au PLATED  
 INTERFACE: MIL-STD-348A

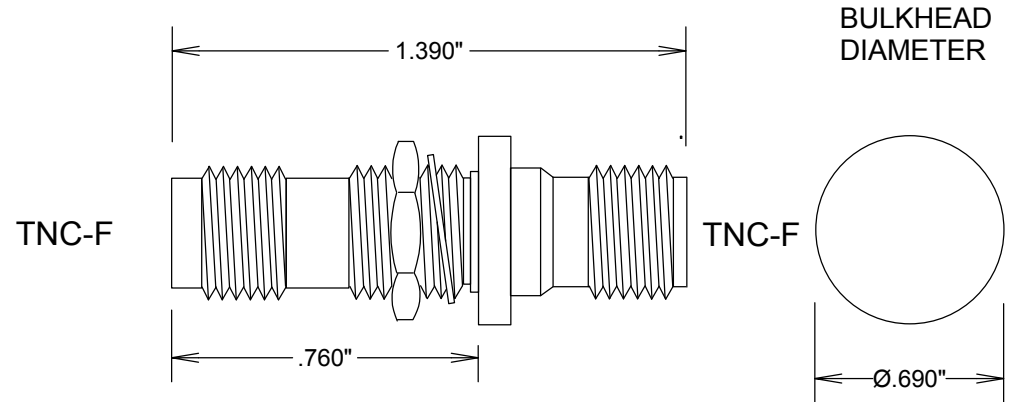

				<b>S. M. ELECTRONICS L.L.C</b>			
				FAIRVIEW, TX 75069 <a href="http://WWW.SMELECTRONICS.US">WWW.SMELECTRONICS.US</a>			
				TITLE			
				TNC F/F BULKHEAD 11 GHZ ADAPTER			
SIZE		CAGE CODE		DWG NO		REV	
<b>A</b>		<b>3FKR5</b>		<b>SM5722</b>			
SCALE				SHEET			