

# SPECIFICATIONS

## ELECTRICAL

FREQUENCY: 0-18 GHZ  
 IMPEDANCE: 50 OHMS  
 VSWR: 1.25:1 MAX

## MECHANICAL

MATERIALS BODY PASS STAINLESS STEEL  
 MATERIALS CONTACTS BeCu  
 CONTACT PLATING: Au MIL-G-45204  
 DURABILITY: 500 CYCLES MIN  
 INTERFACE: MIL-STD 348B

## ENVIRONMENTAL

CORROSION MIL-STD-202  
 VIBRATION MIL-STD-202  
 SHOCK MIL-STD-202

## ROHS COMPLIANT

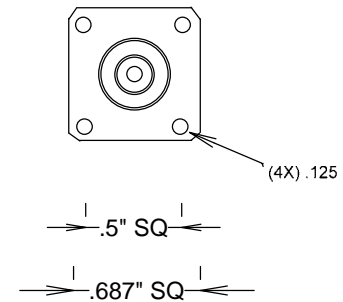
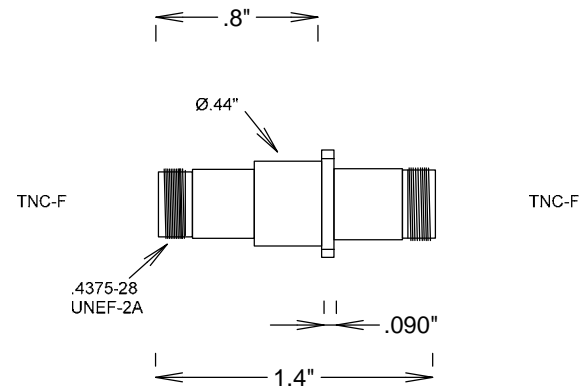

				<b>S. M. ELECTRONICS L.L.C.</b>			
				FAIRVIEW, TX 75069 <a href="http://WWW.SMELECTRONICS.US">WWW.SMELECTRONICS.US</a>			
				TITLE			
				<b>TNC F/F 18GHZ FLANGE ADAPTER</b>			
SIZE		CAGE CODE		DWG NO		REV	
<b>A</b>		<b>3FKR5</b>		<b>SM5725</b>		<b>A</b>	
SCALE				SHEET			