

SPECIFICATIONS

ELECTRICAL

FREQUENCY: 0-6 GHZ
 IMPEDANCE: 50 OHMS
 VSWR: 1.3:1 MAX

MECHANICAL

MATERIALS BODY : NICKEL PLATED BRASS
 CONTACTS: BeCu, Au PLATED
 INTERFACE: MIL-STD-348A

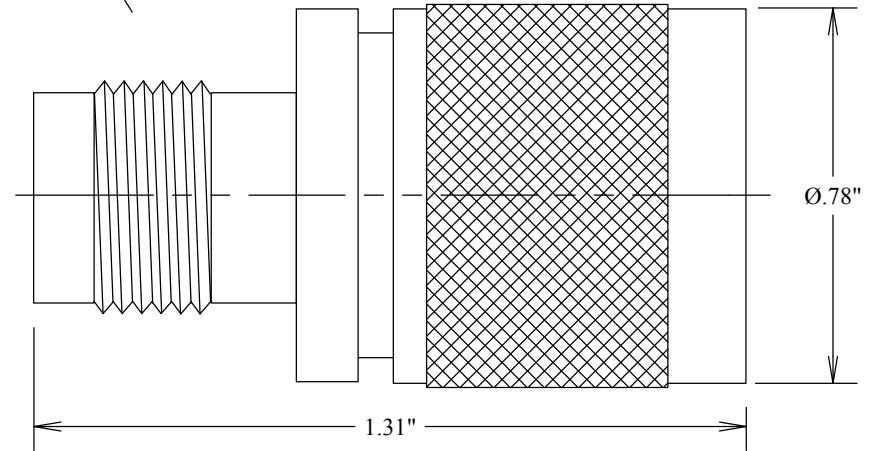
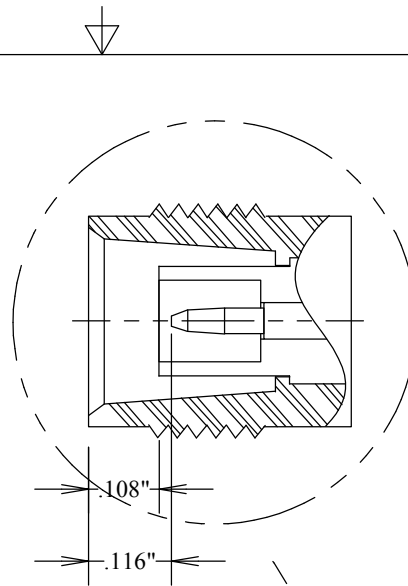

				S. M. ELECTRONICS L.L.C	
				FAIRVIEW, TX 75069 WWW.SMELECTRONICSLLC.COM	
				TITLE	
				N/M-TNC/F REVERSE POLARITY	
		SIZE	CAGE CODE	DWG NO	REV
		A	3FKR5	SM5791	--
				SCALE	SHEET