

# SPECIFICATIONS

## ELECTRICAL:

FREQUENCY: 0-26.5 GHZ

IMPEDANCE: 50 OHMS

VSWR: 1.2:1 MAX

## MECHANICAL:

MATERIAL SMP BODY: BeCu

MATERIAL SMA BODY: PASS S STEEL

CENTER CONTACTS: BeCu

PLATING: Au PER MIL-G-45204

INSULATOR: PTFE

INTERFACE: SMA MIL-STD-348B

OP. TEMP RANGE: -55° to +125°C

ROHS COMPLIANT

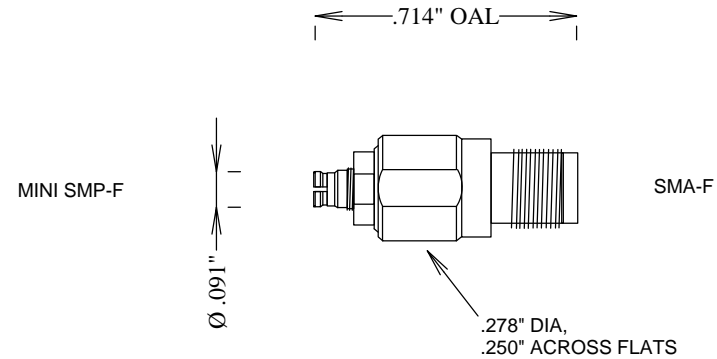

**S. M. ELECTRONICS L.L.C.**

FAIRVIEW, TX 75069 WWW.SMELECTRONICS.US

TITLE

**ADAPTER MINI-SMP/F-SMA/F 26.5GHZ**

SIZE	CAGE CODE	DWG NO	REV
<b>A</b>	<b>3FKR5</b>	<b>SM8902</b>	<b>--</b>

SCALE	SHEET
-------	-------