

# SPECIFICATIONS

## ELECTRICAL:

FREQUENCY: 0-3 GHZ  
 VSWR @ 1 GHZ: 1.15:1 MAX  
 VSWR @ 2.4 GHZ: 1.2:1 MAX  
 VSWR @ 3 GHZ: 1.25 MAX  
 POWER (AVG) 50 WATTS @ 25 DEG C  
 POWER (PEAK) 2000 WATTS  
 ATTENUATION ACCURACY: GREATER OF  
 +/-0.5DB OR 3%  
 IMPEDANCE: 50 OHMS

## ENVIRONMENTAL:

TEMP: -55 C TO +125 C

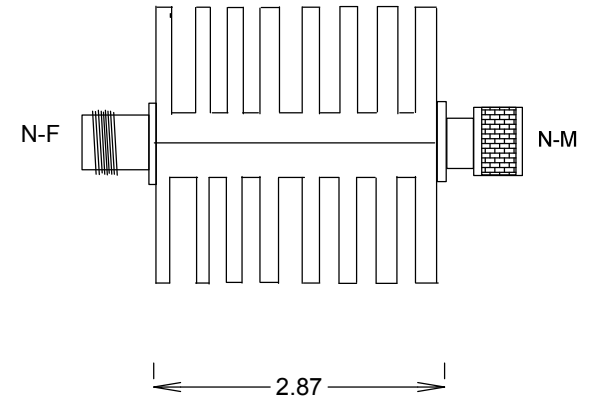
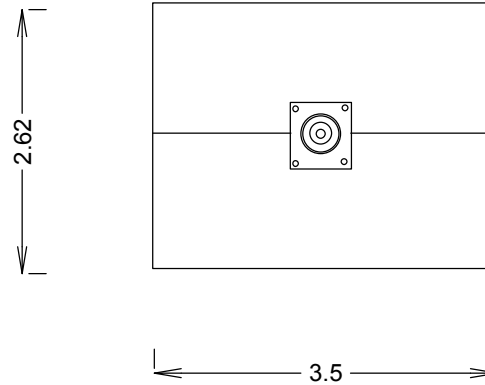

				<b>FAIRVIEW MICROWAVE</b>	
				ALLEN, TX 75013 WWW.FAIRVIEWMICROWAVE.COM	
				TITLE	
				<b>ATTENUATORS N 50 WATTS 3GHZ</b>	
SIZE	CAGE CODE	DWG NO			REV
<b>A</b>		<b>SA3N50-XX</b>			
SCALE					SHEET