

# SPECIFICATIONS

## ELECTRICAL:

FREQUENCY: 0-4 GHZ  
 VSWR 1.2:1 MAX  
 POWER (AVG) 25 WATTS @ 25 °C  
 DERATES TO 2.5WATTS @ 125 °C  
 ATTENUATION ACCURACY:  
 1-30DB: +/- 0.6DB; 40 DB +/- 1DB  
 IMPEDANCE: 50 OHMS

## CONNECTORS:

MATERIAL BODY: PASS STAINLESS STEEL  
 MATERIAL CONTACTS: BeCu  
 CONTACT PLATING: Au, MIL-G-45205  
 INTERFACE: MIL-STD-348A

## ENVIRONMENTAL:

TEMP: -55 C TO +125 C

REQUIRES MOUNTING ON FLAT CONDUCTIVE PLATE

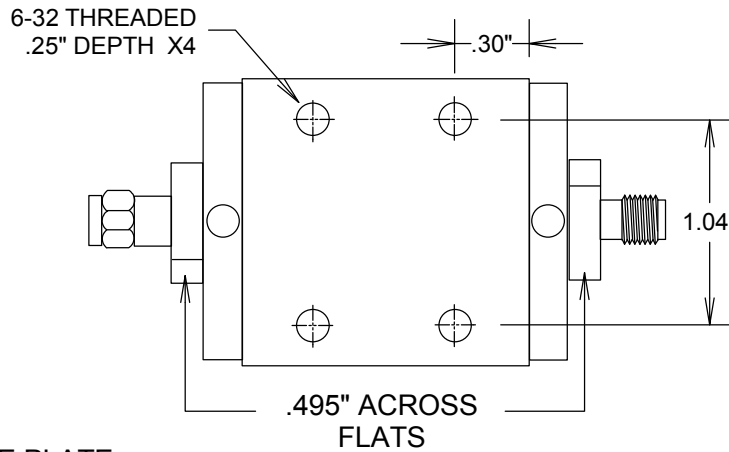
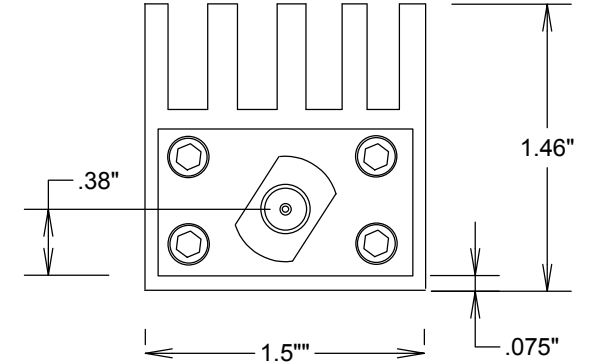
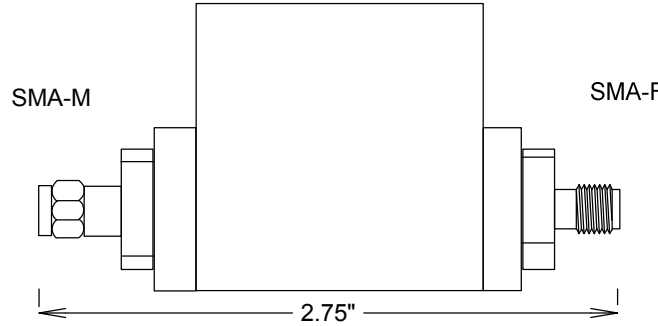

**FAIRVIEW MICROWAVE**

ALLEN, TX 75013 WWW.FAIRVIEWMICROWAVE.COM

TITLE

**ATTENUATORS SMA 25 WATTS 4GHZ**

SIZE	CAGE CODE	DWG NO	REV
<b>A</b>	3FKR5	<b>SA4S25-XX</b>	<b>A</b>
SCALE		SHEET	