

SPECIFICATIONS

ELECTRICAL:

FREQUENCY: 0-4 GHZ
 IMPEDANCE: 50 OHMS
 OP. TEMP RANGE: -55°C to +155°C

MECHANICAL:

MATERIAL BODY: BRASS NI PLATING
 CENTER CONTACT: BeCu
 CONTACT PLATING: Au PER MIL-G-45204
 INSULATOR: TEFLON
 INTERFACE: MIL-STD-883A

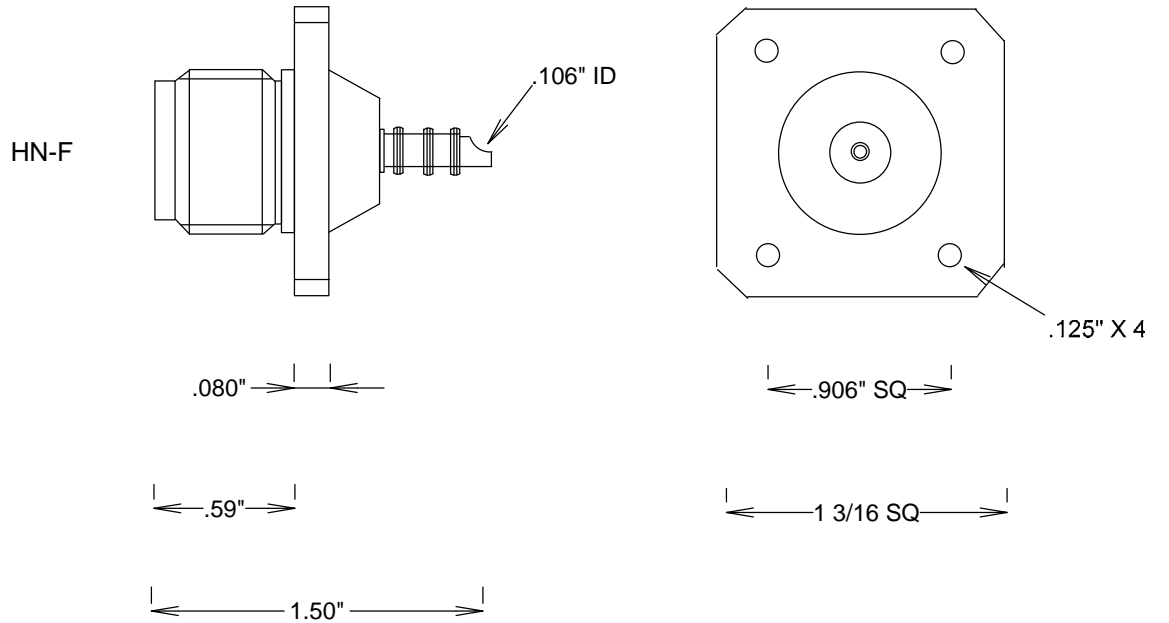

S. M. ELECTRONICS L.L.C.
 FAIRVIEW, TX 75069 WWW.SMELECTRONICS.US

TITLE

HN-F PANEL MOUNT SOLDER POT

SIZE	CAGE CODE	DWG NO	REV
A	3FKR5	SC4819	--
SCALE	SHEET		