

ASSEMBLY INSTRUCTIONS

1.0 PREPARING THE CABLE

- 1.1 TRIM THE CABLE TO DIMENSIONS SHOWN
- 1.2 FILE THE BLUNT END OF THE CABLE INNER CONDUCTOR TO A 60° / 90° CONE
- 1.3 REMOVE BURRS AND SHARPEN EDGES FROM OUTER CONDUCTOR WITH SCOTCH BRITE
- 1.4 DIP PREPARED END OF CABLE INTO FLUX, THEN INTO SOLDER POT APPROXIMATELY 1/2 INCH FORMING A THIN COAT OF TIN ON THE OUTER AND INNER CONDUCTOR. THEN REMOVE EXCESS SOLDER, IF NEEDED, AND CLEAN WITH SOLVENT.

2.0 SOLDERING CENTER CONTACT TO INNER CABLE CONDUCTOR

- 2.1 PLACE SHIM ON CENTER CONDUCTOR RESTING FIRMLY AGAINST CABLE DIELECTRIC
- 2.2 HEAT CENTER CONTACT AND SLIDE IT OVER THE INNER CONDUCTOR TO REST FIRMLY AGAINST SHIM.
- 2.3 SOLDER CONTACT AS SHOWN USING 60/40.
- 2.4 REMOVE EXCESS SOLDER AND CLEAN WITH SOLVENT.

3.0 SOLDERING CABLE SUB-ASSEMBLY TO BODY

- 3.1 FORM A RING(360°) WITH .010 SOLDER AROUND CABLE.
- 3.2 THREAD MATING TOOL INTO CONNECTOR.
- 3.3 INSERT CABLE SUB-ASSEMBLY INTO BACK OF CONNECTOR HOUSING UNTIL IT BOTTOMS. PLACE INTO FIXTURE AND CLAMP CABLE TO PREVENT MOVEMENT WHILE SOLDERING.
- 3.4 USING RESISTIVE SOLDERING IRON, HEAT HOUSING(HOLDING DOWNWARDS) UNTIL SOLDER FLOWS EVENLY AROUND CABLE AND HOUSING.
- 3.5 REMOVE MATING TOOL AND CLEAN SOLDER JOINT WITH SOLVENT(ALCOHOL). VERIFY THAT SOLDER IS FREE OF VOIDS.
- 3.6 INSPECT CENTER CONTACT LENGTH FROM REFERENCE PLANE(.052/.058)

CAUTION: AVOID USING CLEANING FLUIDS CONTAINING HALOGENATED AND AROMATIC HYDROCARBONS, THESE CHEMICALS CAN CAUSE DAMAGE TO THE CENTER CONDUCTOR SUPPORT BEND. USE ISOPROPYL ALCOHOL FOR CLEANING PROCEDURES.

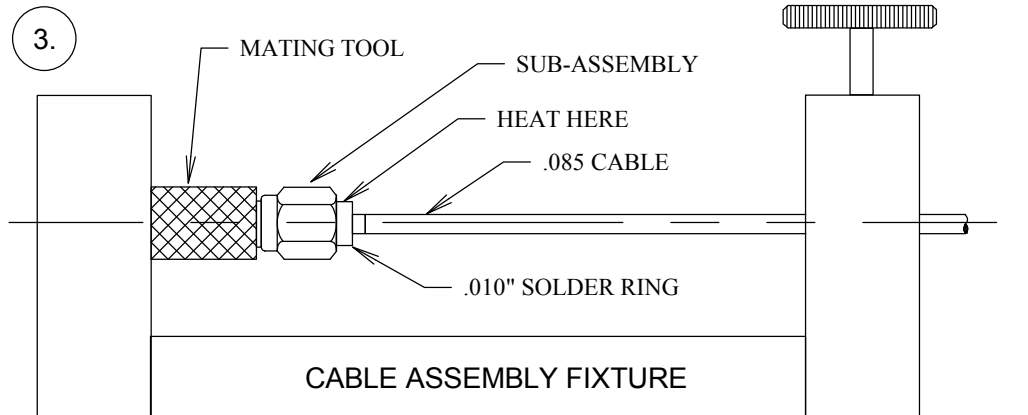
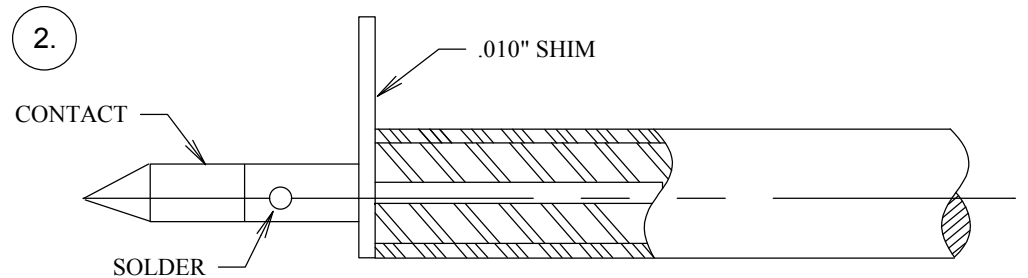
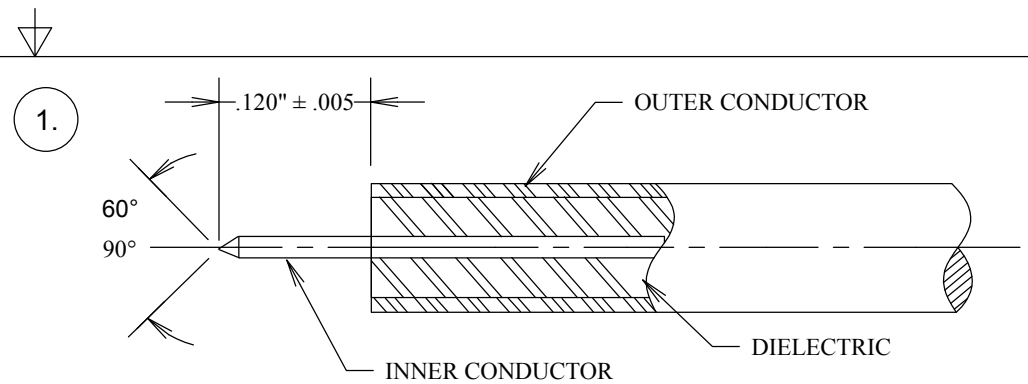

S. M. ELECTRONICS L.L.C
 FAIRVIEW, TX 75069 WWW.SMELECTRONICS.US

TITLE			
2.92mm M .085 SEMI-RIGID			
SIZE	CAGE CODE	DWG NO	REV
A	3FKR5	SMC292-085M	--
SCALE		SHEET	