

SPECIFICATIONS

ELECTRICAL:

FREQUENCY: 1-4 GHZ
 VSWR 1.20:1 MAX
 POWER CW: 50 WATTS
 POWER PEAK: 3KW
 DIRECTIVITY: 23 DB MIN
 TRUE LOSS: THRU: 6DB: 2.0DB
 TRUE LOSS: THRU: 10DB: 0.9DB
 TRUE LOSS: THRU: 20DB: 0.45DB
 IMPEDANCE: 50 OHMS

MECHANICAL:

CONNECTORS: PASS. STAINLESS STEEL
 CONTACTS: Au PLATED

ENVIRONMENTAL:

TEMP: -55 C TO +125 C

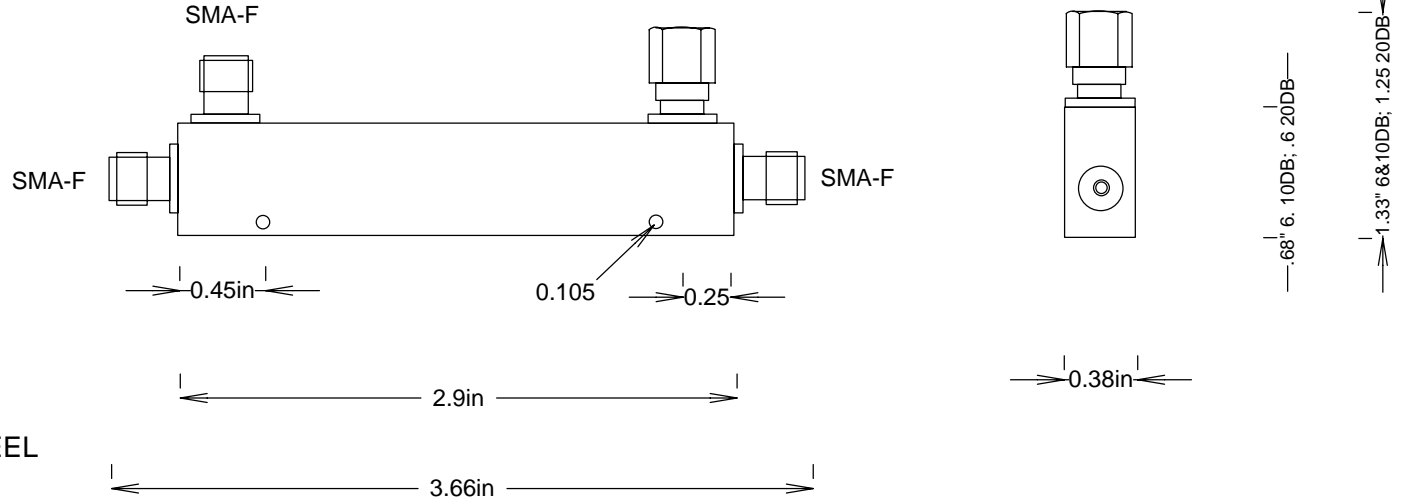

DBd
 Communications
 Line Card

S. M. ELECTRONICS

FAIRVIEW, TX 75069 WWW.SMELECTRONICS.US

TITLE

SMA DIRECTIONAL COUPLERS 1-4GHZ

SIZE	CAGE CODE	DWG NO.	REV
A	3FKR5	MC2034	A
SCALE		SHEET	