

SPECIFICATIONS

ELECTRICAL

FREQUENCY: 0-7.5 GHZ
 IMPEDANCE: 50 OHMS
 VSWR: 1.1:1 MAX @ 4GHZ; 1.2 @ 8GHZ

MECHANICAL

MATERIALS BODY TRIMETAL PLATED BRASS
 MATERIALS CONTACTS Si PLATING
 RECOMMENDED TORQUE 221 IN-LBS

ENVIRONMENTAL PER DIN 47223

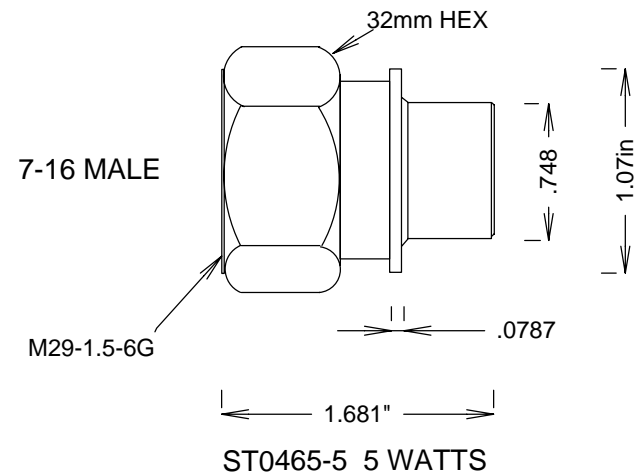
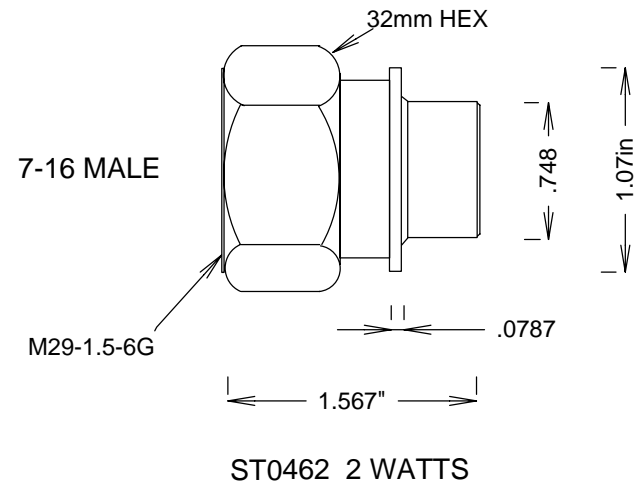

S. M. ELECTRONICS

FAIRVIEW, TX WWW.SMELECTRONICS.US

TITLE

7/16 MALE TERMINATIONS 2, 5 WATTS

SIZE	CAGE CODE	DWG NO	REV
A	3FKR5	ST0462, ST0465-5	--

SCALE

SHEET