

SPECIFICATIONS

ELECTRICAL:

FREQUENCY: 0-3 GHZ
 VSWR @ 3 GHZ: 1.15:1 MAX
 POWER (AVG) 2 WATTS @ 25 DEG C
 POWER (PEAK) 1KW/50 MICRO-S
 IMPEDANCE: 50 OHMS
 OP. TEMP RANGE: -55C- +125C

MECHANICAL:

MATERIAL BODY: BRASS
 BODY PLATING :

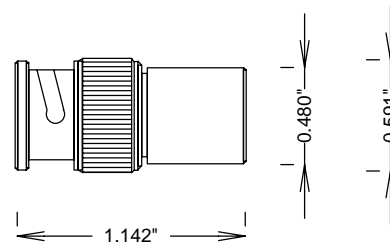

ST3B

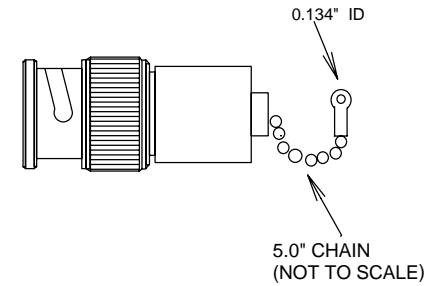

ST3B-C

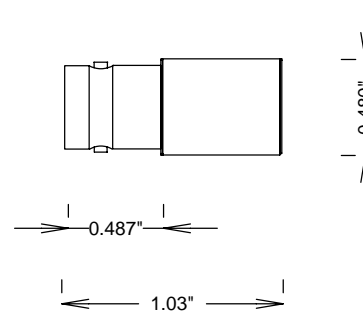

ST3B-F

				S. M. ELECTRONICS	
				FAIRVIEW, TX WWW.SMELECTRONICS.US	
				TITLE	
				TERMINATIONS 3GHZ BNC	
SIZE	CAGE CODE	DWG NO	REV		
A	3FKR5	ST3B , ST3BC, ST3B-F	B		
SCALE			SHEET		