

SPECIFICATIONS

ELECTRICAL:

FREQUENCY: 0-18 GHZ
 VSWR @ 18 GHZ: 1.25:1 MAX
 POWER (AVG) 2 WATTS @ 25 DEG C
 DERATES LINERLY TO 1W @ 125 DEG C
 POWER (PEAK) 1KW/50 MICRO-S
 IMPEDANCE: 50 OHMS
 OP. TEMP RANGE: -55C- +125C

MECHANICAL:

MATERIAL BODY: BRASS w TRI-METAL PLATING
 CENTER CONTACT: GOLD PLATED PER MIL-G-45204
 RESISTIVE ELEMENT: THIN FILM ON ALUMINA SUBSTRATE

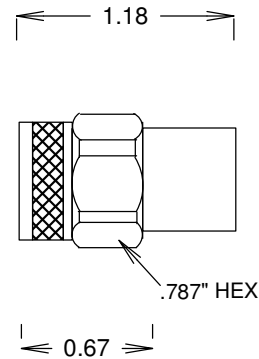

STN1811

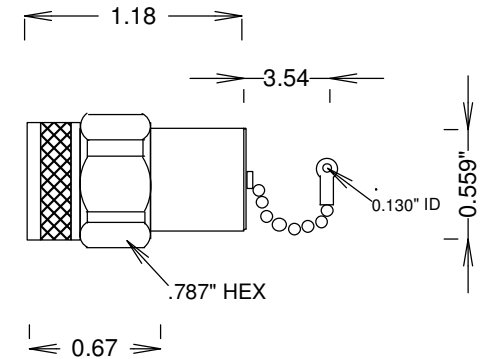

STN1811C

S. M. ELECTRONICS

FAIRVIEW, TEXAS WWW.SMELECTRONICS.US

TITLE

TERMINATION 18GHZ N-MALE

SIZE	CAGE CODE	DWG NO	REV
A		STN1811 , STN1811C	A
SCALE	SHEET		